

DESK ASSEMBLY INSTRUCTIONS

REV #	REVISION DESCRIPTION	DATE
*	*	** ** *

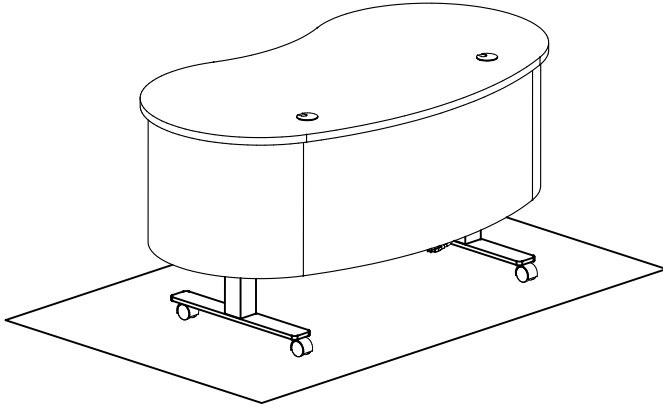

ASSEMBLED DESK- FRONT VIEW
TOP LOWERED

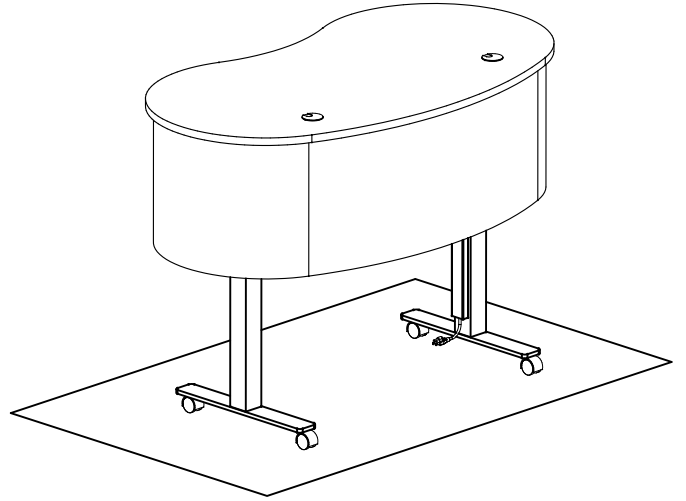

ASSEMBLED DESK- FRONT VIEW
TOP @ FULL EXTENSION

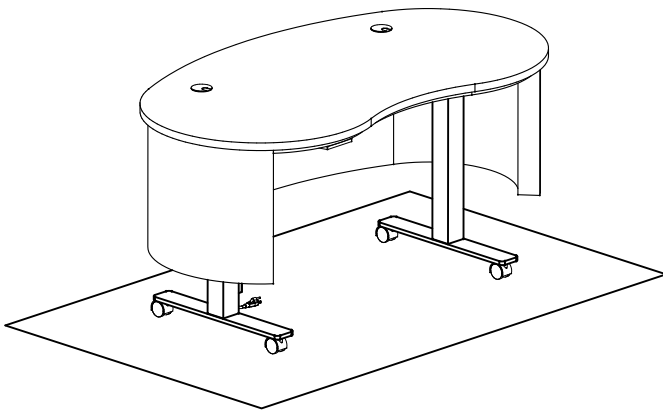

ASSEMBLED DESK- BACK VIEW
TOP LOWERED

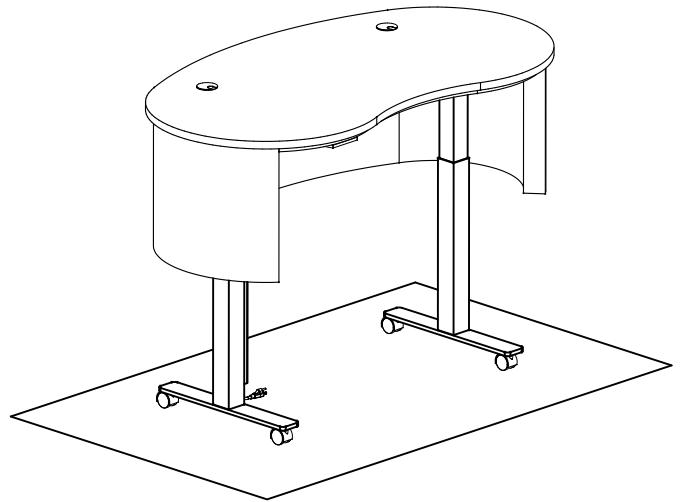

ASSEMBLED DESK- BACK VIEW
TOP @ FULL EXTENSION

KURVE COLLECTION

3branch
product design solutions

P 847.291.3900
F 847.291.3901
www.3branch.com

DESCRIPTION: KURVE DESK W/MOTORIZED ADJUSTABLE
HEIGHT "T" BASE
ASSEMBLY INSTRUCTIONS

DATE: 08.08.22

DWG # SK-KU-DESK-EADJT-ASSEMBLY-01

REV # 0

SHEET 1 OF 7

PARTS LIST:

TOP PANEL	QTY= 1
APRON/SUB-TOP ASSEMBLY	QTY= 1
BASE ADJUSTABLE HEIGHT COLUMNS	QTY= 2
BASE MAIN BARS	QTY= 2
BASE MOUNTING PLATES	QTY= 2
CONTROL BOX	QTY= 1
POWER CORD	QTY= 1
CORD EXTENSION MALE-MALE	QTY= 2
KEYPAD	QTY= 1

HARDWARE:

M8 X 25MM MACHINE SCREWS	QTY= 8
M8 X 35MM MACHINE SCREWS	QTY= 8
#12 X 1" L PHILLIPS ROUND HEAD WOOD SCREWS, STEEL W/BLACK FINISH	QTY= 8
#8 X 1 1/2" L PHILLIPS FLAT HEAD SHEET METAL SCREWS	QTY= 9
#12 X 1" L PHILLIPS FLAT HEAD SHEET METAL SCREWS	QTY= VARIES
#8 X 3/4" L PHILLIPS FLAT HEAD SHEET METAL SCREWS	QTY= VARIES
CABLE CLAMP 0.76" I.D.	QTY= 3
CABLE CLAMP 0.31" I.D.	QTY= 1
CASTERS, 2" DIA WHEEL, 5/16"-18X 1/2" L STEM	QTY= 4
LEVELERS, 5/16"-18X 1/2" L STEM (OPTIONAL)	QTY= 4
SILICONE ADHESIVE (SOLID SURFACE TOP ONLY)	QTY= 4

ELECTRICAL/WIRE MANAGEMENT:

2" DIA GROMMET	QTY= 2
MAGNETIC WIRE CHANNEL	QTY= 1
WIRE TRAY (OPTIONAL)	
POWER STRIP (OPTIONAL)	

TOOLS REQ'D:

- #2 PHILLIPS SCREW DRIVER/BIT (TOP MOUNTING)
- #3 PHILLIPS SCREW DRIVER/BIT ("T" BASE MOUNTING)
- 5MM HEX HEAD DRIVER/BIT ("T" BASE ASSEMBLY)
- 14MM OPEN WRENCH (CASTER MOUNTING)

NOTE:

WORKSURFACE HEIGHT ADJUSTABLE FROM 29 3/4" TO 42".

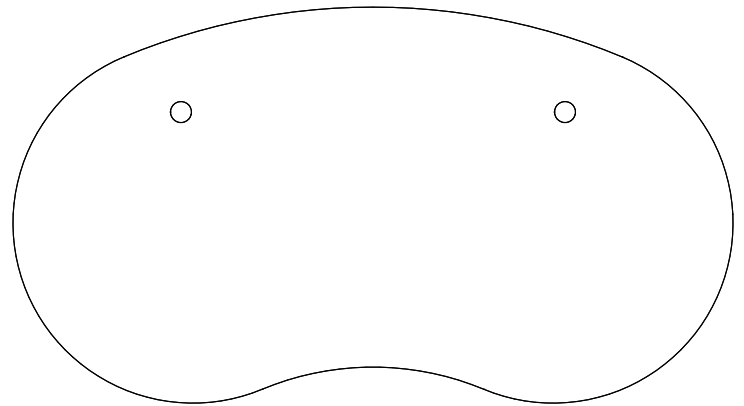

TOP PANEL

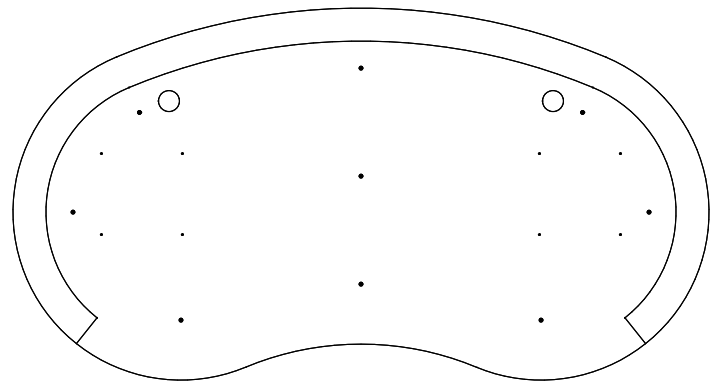

APRON/SUB-TOP ASSEMBLY

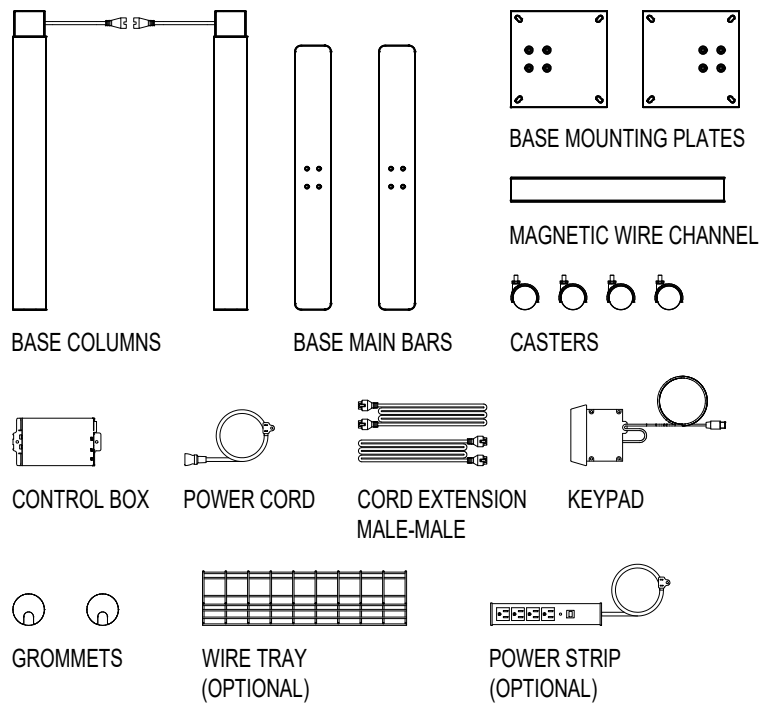

KURVE COLLECTION

3branch
product design solutions

P 847.291.3900
F 847.291.3901
www.3branch.com

DESCRIPTION: KURVE DESK W/MOTORIZED ADJUSTABLE HEIGHT "T" BASE ASSEMBLY INSTRUCTIONS

NOTE: THE FOLLOWING ASSEMBLY INSTRUCTIONS APPLY TO ALL SHAPES & SIZES OF KURVE DESKS.

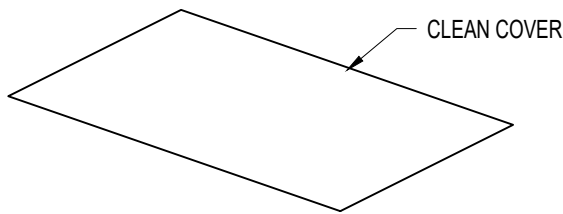

STEP 1:
 REMOVE ALL PACKING MATERIAL FROM DESK TOP PANEL, APRON/SUB-TOP ASSEMBLY, BASE PARTS & TOP.
 UNBOX & LAY OUT ALL MOTORIZED BASE COMPONENTS

***CAUTION: TWO PEOPLE REQ'D FOR DESK ASSEMBLY TO AVOID DAMAGE TO DESK PARTS & PERSONAL INJURY!**

STEP 2:
 LAY CLEAN COVER ON FLOOR TO PROTECT FLOOR & DESK PARTS.

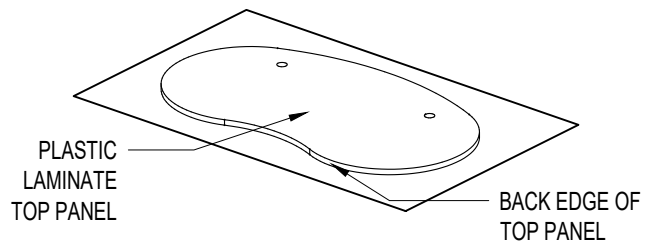

STEP 3:
 LAY PLASTIC LAMINATE TOP PANEL ON CLEAN COVER WITH GOOD FACE TURNED DOWN.
 NOTE: STEPS 3, 4, & 5 ARE FOR PLASTIC LAMINATE TOPS ONLY. SOLID SURFACE TOPS WILL BE MOUNTED TO APRON/SUB-TOP ASSEMBLY WITH SILICONE ADHESIVE AFTER BASE END ASSEMBLIES ARE ATTACHED. SEE STEP 19.

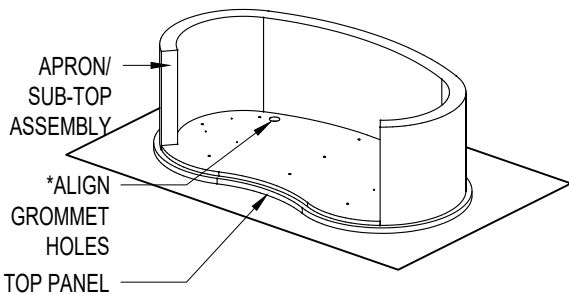

STEP 4:
 LAY APRON/SUB-TOP ASSEMBLY ON BOTTOM FACE OF PLASTIC LAMINATE TOP PANEL.
 *VERIFY THAT GROMMET HOLES IN THE SUB-TOP ALIGN WITH THE GROMMET HOLES IN THE TOP PANEL. THE GROMMET HOLES ARE LOCATED NEAR THE FRONT EDGE OF THE DESK.
 CENTER APRON/SUB-TOP ASSEMBLY FRONT TO BACK & END TO END.
 NOTE: THERE IS AN APPROXIMATE 1" TOP PANEL OVERHANG PAST THE APRON/SUB-TOP ASSEMBLY ON ALL SIDES AND ENDS.
 NOTE: APRON/SUB-TOP ASSEMBLY MAY SHIP WITH TOP PANEL ALREADY ATTACHED. IF SO, SKIP STEPS 4 & 5.

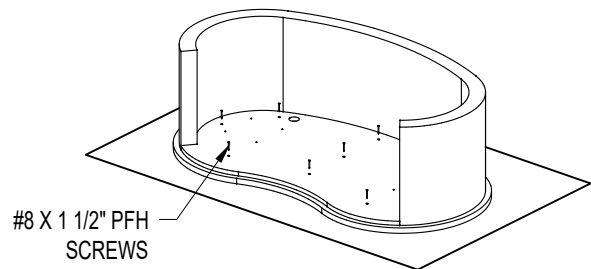

STEP 5:
 ATTACH APRON SUB-TOP ASSEMBLY TO TOP PANEL WITH #8 X 1 1/2" PFH SHEET METAL SCREWS. INSERT SCREWS INTO COUNTERSUNK HOLES LOCATED IN SUB-TOP & THREAD INTO BOTTOM FACE OF TOP PANEL.
 NOTE: QUANTITY OF SCREWS WILL VARY WITH SIZE & SHAPE OF DESK.
 NOTE: DO NOT ATTACH APRON/SUB-TOP ASSEMBLY TO ANY SOLID SURFACE TOP WITH SCREWS!!! SOLID SURFACE TOPS WILL BE ATTACHED TO APRON/SUB-TOP ASSEMBLY WITH SILICONE ADHESIVE AFTER BASE END ASSEMBLIES ARE ATTACHED TO APRON/SUB-TOP ASSEMBLY. SEE STEP 19.

KURVE COLLECTION

3branch
 product design solutions

P 847.291.3900
 F 847.291.3901
 www.3branch.com

DESCRIPTION: KURVE DESK W/MOTORIZED ADJUSTABLE HEIGHT "T" BASE ASSEMBLY INSTRUCTIONS

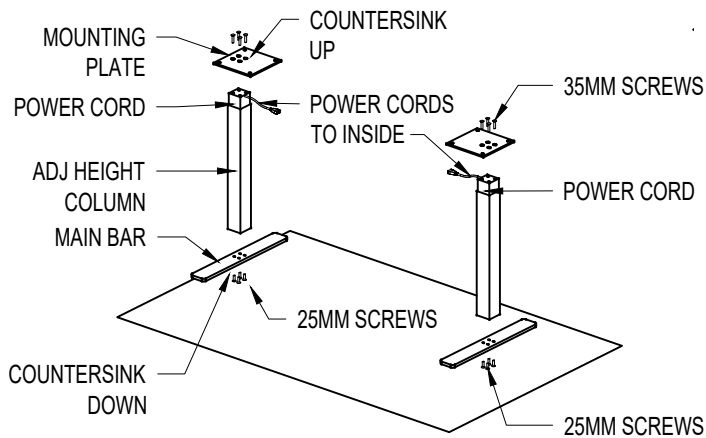

STEP 6:

ORIENATE COLUMNS SO THAT THE POWER CORDS ARE TURNED TOWARDS THE WIDE OVERHANGING SIDE OF THE MOUNTING PLATES. ORIENTATE MOUNTING PLATES SO THAT COUNTERSUNK SCREW HOLES ARE OPPOSITE THE COLUMN.

ATTACH MOUNTING PLATES TO COLUMNS WITH M8 X 35MM 5MM HEX DRIVE SCREWS INSERTED THRU MOUNTING PLATES & THREADING INTO TAPPED HOLES IN COLUMN END (4/END BASE).

STEP 7:

ORIENATE MAIN BARS SO THAT COUNTERSUNK SCREW HOLES ARE OPPOSITE THE COLUMN.

ATTACH MAIN BARS TO COLUMNS WITH M8 X 25MM 5MM HEX DRIVE SCREWS INSERTED THRU COUNTERSUNK HOLES IN MAIN BAR & THREADING INTO TAPPED HOLES IN COLUMN END (4/BASE END).

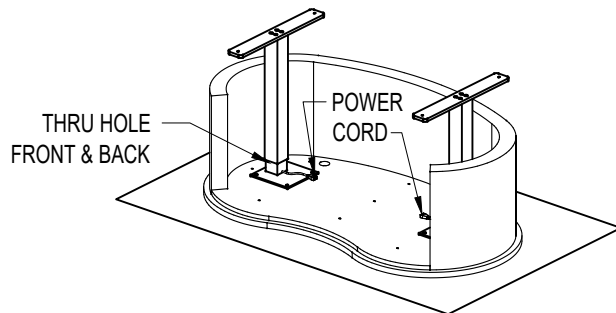

STEP 8:

TURN ASSEMBLED BASE ENDS FROM STEP 7 UPSIDE DOWN & SET ON APRON/SUB-TOP ASSEMBLY.

NOTE: ORIENTATE BOTH COLUMNS SO THAT THE POWER CORDS ARE TO THE INSIDE.

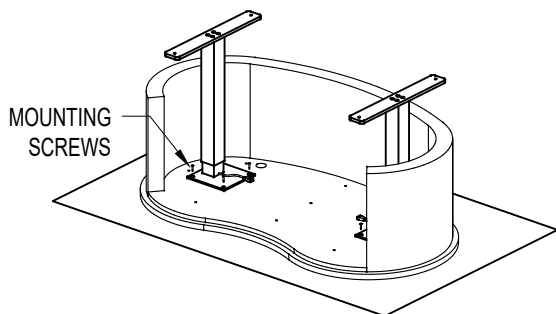

STEP 9:

ALIGN BASE MOUNTING PLATES WITH PILOT HOLES LOCATED IN BOTTOM FACE OF APRON/SUB-TOP ASSEMBLY.

ATTACH BASE ENDS TO BOTTOM FACE OF TOP PANEL WITH #12 X 1" RHP WOOD SCREWS. INSERT SCREWS THRU HOLES IN BASE MOUNTING PLATES & TIGHTEN INTO CORRESPONDING PILOT HOLES LOCATED IN THE BOTTOM FACE OF THE SUB-TOP. NOTE: FOUR SCREWS REQ'D FOR EACH BASE END.

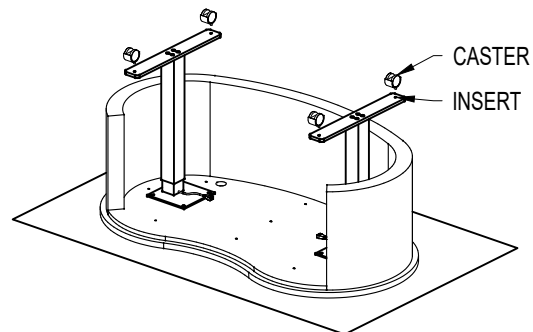

STEP 10:

THREAD CASTER STEMS INTO THREADED INSERTS LOCATED IN THE BOTTOM OF THE BASE ASSEMBLY. TIGHTEN CASTER STEMS WITH 14MM OPEN END WRENCH.

NOTE: BASE IS ALSO AVAILABLE WITH OPTIONAL LEVELERS.

KURVE COLLECTION

3branch
product design solutions

P 847.291.3900
F 847.291.3901
www.3branch.com

DESCRIPTION: KURVE DESK W/MOTORIZED ADJUSTABLE HEIGHT "T" BASE ASSEMBLY INSTRUCTIONS

DATE: 08.08.22

DWG # SK-KU-DESK-EADJT-ASSEMBLY-01

REV # 0

SHEET 4 OF 7

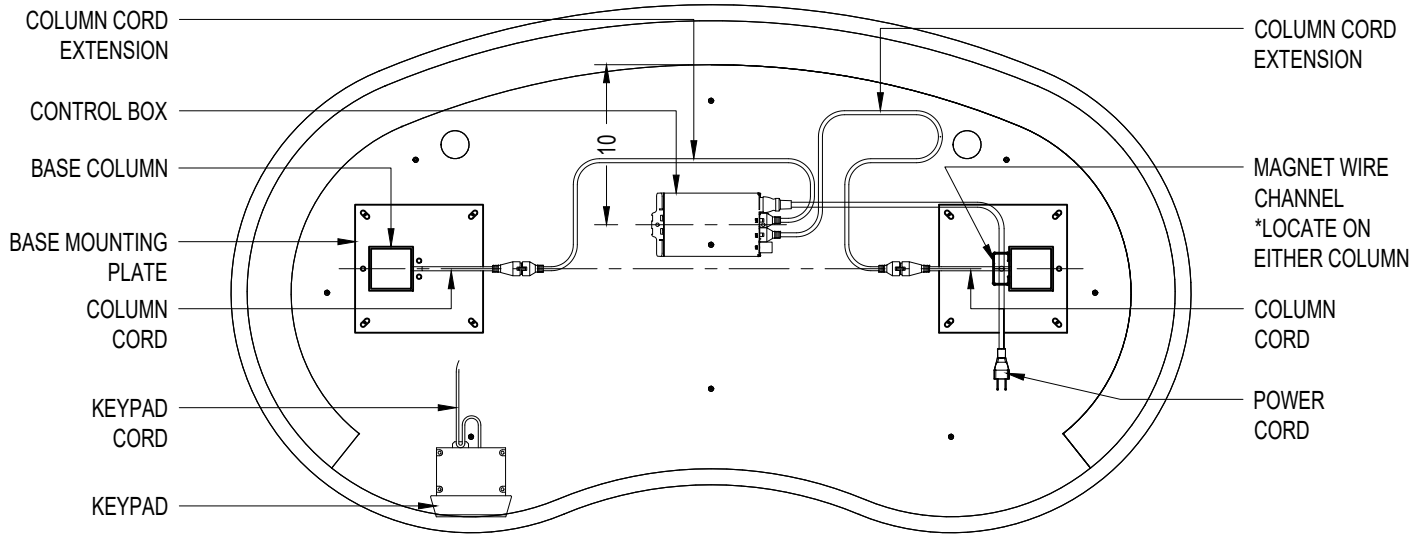

MOTORIZED BASE WIRING DIAGRAM

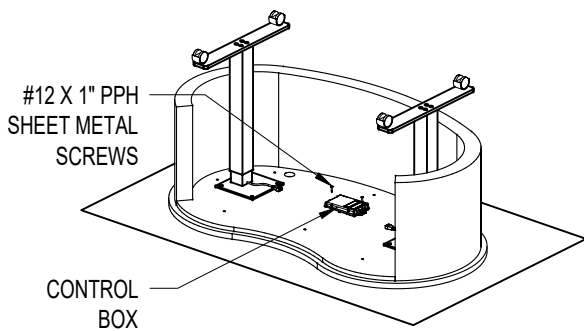

STEP 11:
 LOCATE CONTROL BOX ON BOTTOM THE FACE OF SUB-TOP @ THE CENTER BETWEEN COLUMNS. OFFSET THE CONTROL BOX 10" FROM THE INSIDE FACE OF THE APRON TO THE CENTER OF THE CONTROL BOX. MARK MOUNTING HOLE CENTERS (x4) AND THEN BORE 1/8"DIA X 3/4"D PILOT HOLES.
 ATTACH CONTROL BOX TO SUB-TOP WITH #12 X 1" PPH SHEET METAL SCREWS.

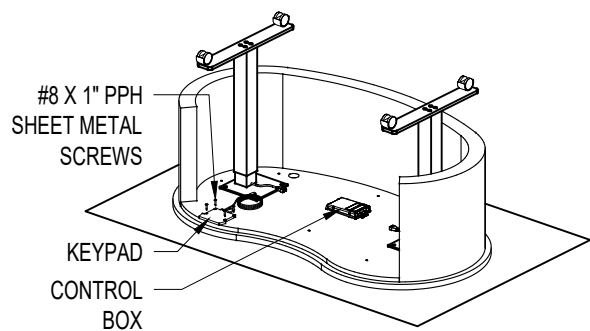

STEP 12:
 LOCATE KEYPAD @ DESIRED LOCATION ON BOTTOM FACE OF SUB-TOP.
 MARK MOUNTING HOLE CENTERS (x4) AND THEN BORE 1/8"DIA X 3/4"D PILOT HOLES.
 ATTACH KEYPAD TO SUB-TOP WITH #8 X 3/4" PPH SHEET METAL SCREWS.

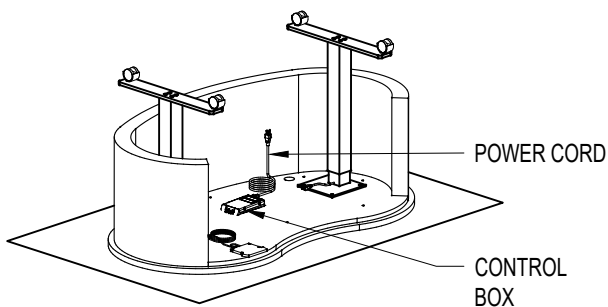

STEP 13:
 CONNECT POWER CORD TO CONTROL BOX AS SHOWN.

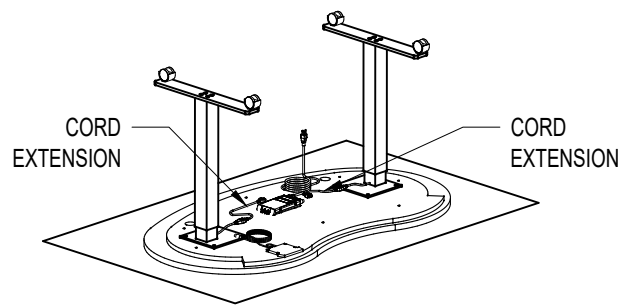

STEP 14:
 CONNECT CORD EXTENSIONS TO COLUMN CORDS AS SHOWN.
 *APRON REMOVED FOR CLARITY.

KURVE COLLECTION

3branch
 product design solutions

P 847.291.3900
 F 847.291.3901
 www.3branch.com

DESCRIPTION: KURVE DESK W/MOTORIZED ADJUSTABLE HEIGHT "T" BASE ASSEMBLY INSTRUCTIONS

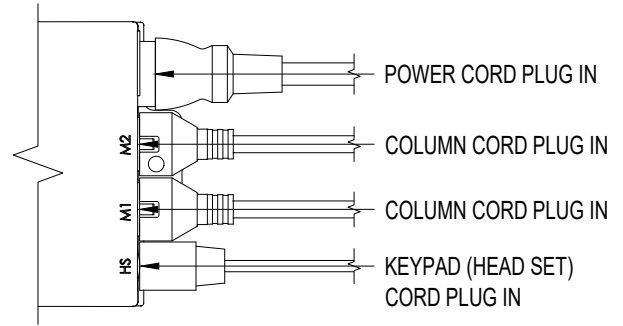
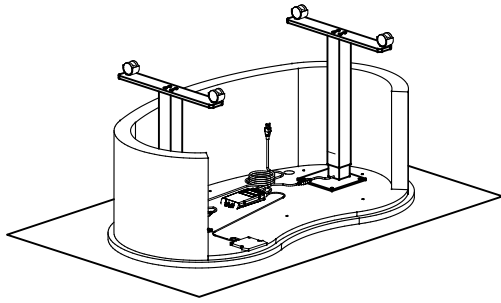

ENLARGED DETAIL OF CONTROL BOX CONNECTIONS

STEP 15:
 CONNECT KEYPAD AND COLUMN CORD EXTENSIONS TO CONTROL BOX.
 *SEE ENLARGED DETAIL OF CONTROL BOX CONNECTIONS.

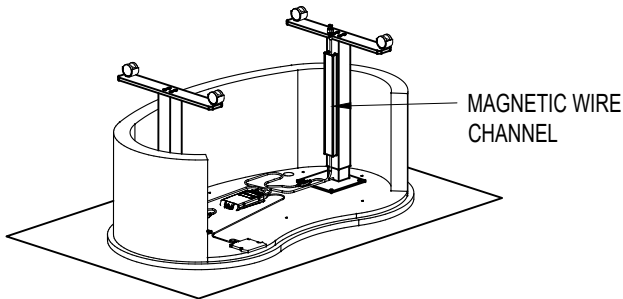

MAGNETIC WIRE CHANNEL

STEP 16:
 RUN POWER CORD THRU MAGNETIC WIRE CHANNEL.
 MOUNT MAGNETIC WIRE CHANNEL TO DESIRED BASE COLUMN.

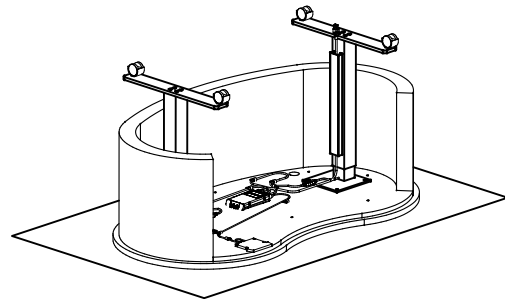

STEP 17:
 USE CABLE CLAMPS AS REQUIRED TO SECURE LOOSE & EXTRA CORDS.
 ATTACH CLAMPS TO SUB-TOP WITH #8 X 3/4" PPH SCREWS.

KURVE COLLECTION

3branch
 product design solutions

P 847.291.3900
 F 847.291.3901
 www.3branch.com

DESCRIPTION: KURVE DESK W/MOTORIZED ADJUSTABLE
 HEIGHT "T" BASE
 ASSEMBLY INSTRUCTIONS

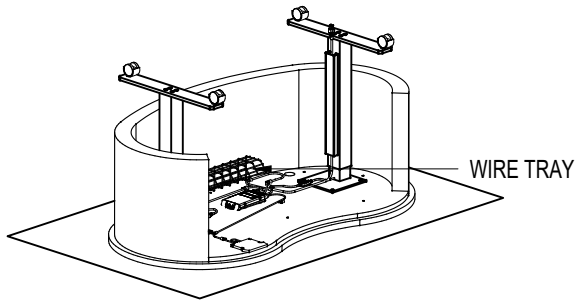

STEP 18: (OPTIONAL)

LOCATE WIRE TRAY @ BACK OF DESK.

NOTE: USE TEMPLATE PROVIDED WITH WIRE TRAY TO LOCATE PILOT HOLES FOR THE MOUNTING SCREWS.

MARK MOUNTING HOLE CENTERS (x9) AND THEN BORE 1/8" DIA X 3/4" D PILOT HOLES.

MOUNT WIRE TRAY TO BOTTOM FACE WITH SCREWS PROVIDED.

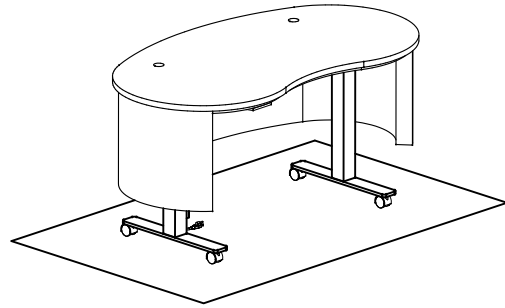

STEP 19:

TURN ASSEMBLED DESK UPRIGHT.

*CAUTION: TWO PEOPLE REQ'D TO TURN TABLE OVER TO AVOID DAMAGE TO DESK PARTS & PERSONAL INJURY!

*CAUTION: DO NOT PIVOT ON TABLE BASE TO AVOID DAMAGE TO BASE!

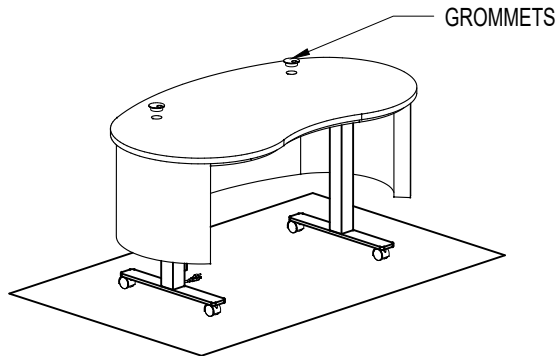

STEP 20:

INSTALL GROMMETS IN HOLES BORED THRU TOP PANEL & APRON/SUB-TOP ASSEMBLY NEAR EACH END.

NOTE: SOLID SURFACE TOP WOULD BE ATTACHED TO APRON/SUB-TOP ASSEMBLY WITH SILICONE ADHESIVE @ THIS STEP IF APPLICABLE.

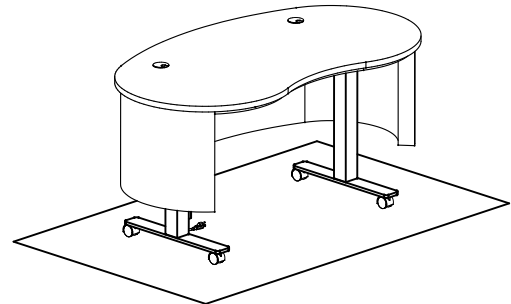

STEP 21:

ROLL ASSEMBLED DESK IN PLACE.

STEP 22:

SEE SEPARATE INSTRUCTIONS FOR KEYPAD OPERATION

KURVE COLLECTION

3branch
product design solutions

P 847.291.3900
F 847.291.3901
www.3branch.com

DESCRIPTION: KURVE DESK W/MOTORIZED ADJUSTABLE
HEIGHT "T" BASE
ASSEMBLY INSTRUCTIONS

DATE: 08.08.22

DWG # SK-KU-DESK-EADJT-ASSEMBLY-01

REV # 0

SHEET 7 OF 7