

**2024
Maker Max Table
Specifications**

General Information

Maker Max Tables are durable, functional work tables for crafting and creating in program spaces. Welded and powder coated steel table end frames provide strength. Heavy-duty casters provide mobility. Three (3) different work surface heights include seated 29", counter 36" & cafe 42". Tops are available in either 1-1/4" thick high pressure laminate, 1-1/2" thick solid maple butcher block and 1" thick phenolic resin. *Note some maple tops are 1-3/4" thick.*

Optional: Adjustable glides available in lieu of heavy-duty casters. Tables are unassembled and ship flat.

Maker Max Table Standards:

Tops are available in laminate, maple butcher block and phenolic resin
 Laminate Worksurface is 1-1/4" thick with PVC edging
 Standard Laminates available from Wilsonart, Formica, Pionite and Nevamar
 Maple Butcher Block is 1-1/2" thick solid maple hardwood
 Phenolic Resin Top is 1" thick phenolic epoxy resin
 Top overhangs table frame 1-1/2" on all sides
 Frame powder coat available in Platinum Metallic, Black, White and Silver.
 Other colors available for 5% upcharge.
 Heavy Duty locking casters
 * Solid surface and quartz are also available. Contact 3branch for options.



ITEM#	DESCRIPTION	WIDTH	DEPTH	HEIGHT
-------	-------------	-------	-------	--------

maker max tables fixed top - seated height 29"h
high pressure laminate top w / PVC edge

MKX-482429-LAM		48	24	29
MKX-483029-LAM		48	30	29
MKX-483629-LAM		48	36	29
MKX-602429-LAM		60	24	29
MKX-603029-LAM		60	30	29
MKX-603629-LAM		60	36	29
MKX-722429-LAM		72	24	29
MKX-723029-LAM		72	30	29
MKX-723629-LAM		72	36	29

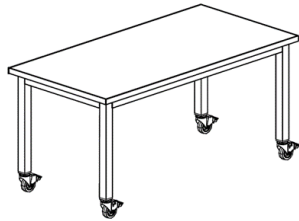

maker max tables fixed top - seated height 29"h
Fixed maple butcher-block Top w / eased edge

MKX-482429-BBK		48	24	29
MKX-483029-BBK		48	30	29
MKX-483629-BBK		48	36	29
MKX-602429-BBK		60	24	29
MKX-603029-BBK		60	30	29
MKX-603629-BBK		60	36	29
MKX-722429-BBK		72	24	29
MKX-723029-BBK		72	30	29
MKX-723629-BBK		72	36	29

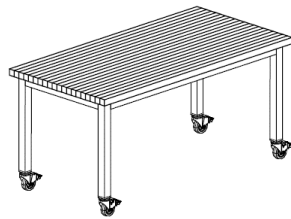

**2024
Maker Max Table
Specifications**

General Information

Maker Max Tables are durable, functional work tables for crafting and creating in program spaces. Welded and powder coated steel table end frames provide strength. Heavy-duty casters provide mobility. Three (3) different work surface heights include seated 29", counter 36" & cafe 42". Tops are available in either 1-1/4" thick high pressure laminate, 1-1/2" thick solid maple butcher block and 1" thick phenolic resin. *Note some maple tops are 1-3/4" thick.*

Optional: Adjustable glides available in lieu of heavy-duty casters. Tables are unassembled and ship flat.

Maker Max Table Standards:

Tops are available in laminate, maple butcher block and phenolic resin
Laminate Worksurface is 1-1/4" thick with PVC edging
Standard Laminates available from Wilsonart, Formica, Pionite and Nevamar
Maple Butcher Block is 1-1/2" thick solid maple hardwood
Phenolic Resin Top is 1" thick phenolic epoxy resin
Top overhangs table frame 1-1/2" on all sides
Frame powder coat available in Platinum Metallic, Black, White and Silver.
Other colors available for 5% upcharge.
Heavy Duty locking casters
* Solid surface and quartz are also available. Contact 3branch for options.



ITEM#	DESCRIPTION	WIDTH	DEPTH	HEIGHT
-------	-------------	-------	-------	--------

maker max tables fixed top - seated height 29" h
high pressure laminate top w / PVC edge

- MKX-36-29-LAM
- MKX-42-29-LAM
- MKX-48-29-LAM

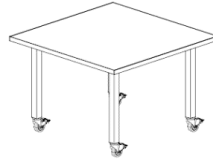

- 36" dia 29
- 42" dia 29
- 48" dia 29

- MKX-303029-LAM
- MKX-363629-LAM
- MKX-424229-LAM
- MKX-484829-LAM

- 30 30 29
- 36 36 29
- 42 42 29
- 48 48 29

maker max tables fixed top - seated height 29" h
Fixed maple butcher-block Top w / eased edge

- MKX-36-29-BBK (1-3/4" thick)
- MKX-42-29-BBK (1-3/4" thick)
- MKX-48-29-BBK (1-3/4" thick)



- 36" dia 29
- 42" dia 29
- 48" dia 29

- MKX-303029-BBK
- MKX-363629-BBK
- MKX-424229-BBK (1-3/4" thick)
- MKX-484829-BBK (1-3/4" thick)

- 30 30 29
- 36 36 29
- 42 42 29
- 48 48 29

**2024
Maker Max Table
Specifications**

General Information

Maker Max Tables are durable, functional work tables for crafting and creating in program spaces. Welded and powder coated steel table end frames provide strength. Heavy-duty casters provide mobility. Three (3) different work surface heights include seated 29", counter 36" & cafe 42". Tops are available in either 1-1/4" thick high pressure laminate, 1-1/2" thick solid maple butcher block and 1" thick phenolic resin. *Note some maple tops are 1-3/4" thick.*

Optional: Adjustable glides available in lieu of heavy-duty casters. Tables are unassembled and ship flat.

Maker Max Table Standards:

Tops are available in laminate, maple butcher block and phenolic resin
 Laminate Worksurface is 1-1/4" thick with PVC edging
 Standard Laminates available from Wilsonart, Formica, Pionite and Nevamar
 Maple Butcher Block is 1-1/2" thick solid maple hardwood
 Phenolic Resin Top is 1" thick phenolic epoxy resin
 Top overhangs table frame 1-1/2" on all sides
 Frame powder coat available in Platinum Metallic, Black, White and Silver.
 Other colors available for 5% upcharge.
 Heavy Duty locking casters
 * Solid surface and quartz are also available. Contact 3branch for options.



ITEM#	DESCRIPTION	WIDTH	DEPTH	HEIGHT
-------	-------------	-------	-------	--------

maker max tables fixed top - counter height 36" h
high pressure laminate top w / PVC edge

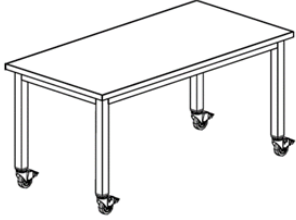
MKX-482436-LAM		48	24	36
MKX-483036-LAM		48	30	36
MKX-483636-LAM		48	36	36
MKX-602436-LAM		60	24	36
MKX-603036-LAM		60	30	36
MKX-603636-LAM		60	36	36
MKX-722436-LAM		72	24	36
MKX-723036-LAM		72	30	36
MKX-723636-LAM		72	36	36

maker max tables fixed top - counter height 36" h
Fixed maple butcher-block Top w / eased edge

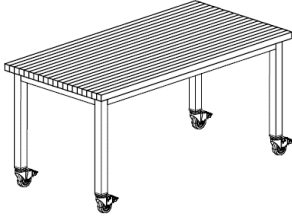
MKX-482436-BBK		48	24	36
MKX-483036-BBK		48	30	36
MKX-483636-BBK		48	36	36
MKX-602436-BBK		60	24	36
MKX-603036-BBK		60	30	36
MKX-603636-BBK		60	36	36
MKX-722436-BBK		72	24	36
MKX-723036-BBK		72	30	36
MKX-723636-BBK		72	36	36

**2024
Maker Max Table
Specifications**

General Information

Maker Max Tables are durable, functional work tables for crafting and creating in program spaces. Welded and powder coated steel table end frames provide strength. Heavy-duty casters provide mobility. Three (3) different work surface heights include seated 29", counter 36" & cafe 42". Tops are available in either 1-1/4" thick high pressure laminate, 1-1/2" thick solid maple butcher block and 1" thick phenolic resin. *Note some maple tops are 1-3/4" thick.*

Optional: Adjustable glides available in lieu of heavy-duty casters. Tables are unassembled and ship flat.

Maker Max Table Standards:

Tops are available in laminate, maple butcher block and phenolic resin
 Laminate Worksurface is 1-1/4" thick with PVC edging
 Standard Laminates available from Wilsonart, Formica, Pionite and Nevamar
 Maple Butcher Block is 1-1/2" thick solid maple hardwood
 Phenolic Resin Top is 1" thick phenolic epoxy resin
 Top overhangs table frame 1-1/2" on all sides
 Frame powder coat available in Platinum Metallic, Black, White and Silver.
 Other colors available for 5% upcharge.
 Heavy Duty locking casters
 * Solid surface and quartz are also available. Contact 3branch for options.



ITEM#	DESCRIPTION	WIDTH	DEPTH	HEIGHT
-------	-------------	-------	-------	--------

maker max tables fixed top - counter height 36" h
high pressure laminate top w / PVC edge

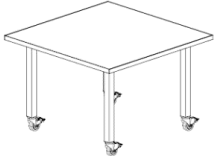
MKX-36-36-LAM		36" dia		36
MKX-42-36-LAM		42" dia		36
MKX-48-36-LAM		48" dia		36
MKX-303036-LAM		30	30	36
MKX-363636-LAM		36	36	36
MKX-424236-LAM		42	42	36
MKX-484836-LAM		48	48	36

maker max tables fixed top - counter height 36" h
Fixed maple butcher-block Top w / eased edge

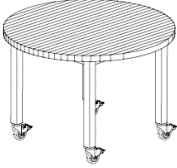
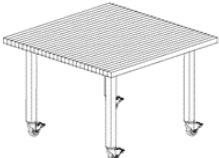
MKX-36-36-BBK (1-3/4" thick)		36" dia		36
MKX-42-36-BBK (1-3/4" thick)		42" dia		36
MKX-48-36-BBK (1-3/4" thick)		48" dia		36
MKX-303036-BBK		30	30	36
MKX-363636-BBK		36	36	36
MKX-424236-BBK (1-3/4" thick)		42	42	36
MKX-484836-BBK (1-3/4" thick)		48	48	36

**2024
Maker Max Table
Specifications**

General Information

Maker Max Tables are durable, functional work tables for crafting and creating in program spaces. Welded and powder coated steel table end frames provide strength. Heavy-duty casters provide mobility. Three (3) different work surface heights include seated 29", counter 36" & cafe 42". Tops are available in either 1-1/4" thick high pressure laminate, 1-1/2" thick solid maple butcher block and 1" thick phenolic resin. *Note some maple tops are 1-3/4" thick.*

Optional: Adjustable glides available in lieu of heavy-duty casters. Tables are unassembled and ship flat.

Maker Max Table Standards:

Tops are available in laminate, maple butcher block and phenolic resin
 Laminate Worksurface is 1-1/4" thick with PVC edging
 Standard Laminates available from Wilsonart, Formica, Pionite and Nevamar
 Maple Butcher Block is 1-1/2" thick solid maple hardwood
 Phenolic Resin Top is 1" thick phenolic epoxy resin
 Top overhangs table frame 1-1/2" on all sides
 Frame powder coat available in Platinum Metallic, Black, White and Silver.
 Other colors available for 5% upcharge.
 Heavy Duty locking casters
 * Solid surface and quartz are also available. Contact 3branch for options.



ITEM#	DESCRIPTION	WIDTH	DEPTH	HEIGHT
-------	-------------	-------	-------	--------

maker max tables fixed top - cafe height 42"h
high pressure laminate top w / PVC edge

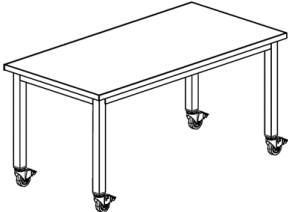
MKX-482442-LAM		48	24	42
MKX-483042-LAM		48	30	42
MKX-483642-LAM		48	36	42
MKX-602442-LAM		60	24	42
MKX-603042-LAM		60	30	42
MKX-603642-LAM		60	36	42
MKX-722442-LAM		72	24	42
MKX-723042-LAM		72	30	42
MKX-723642-LAM		72	36	42

maker max tables fixed top - cafe height 42"h
Fixed maple butcher-block Top w / eased edge

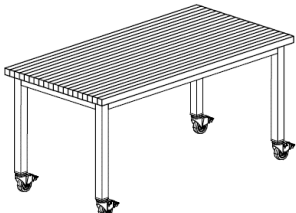
MKX-482442-BBK		48	24	42
MKX-483042-BBK		48	30	42
MKX-483642-BBK		48	36	42
MKX-602442-BBK		60	24	42
MKX-603042-BBK		60	30	42
MKX-603642-BBK		60	36	42
MKX-722442-BBK		72	24	42
MKX-723042-BBK		72	30	42
MKX-723642-BBK		72	36	42

**2024
Maker Max Table
Specifications**

General Information

Maker Max Tables are durable, functional work tables for crafting and creating in program spaces. Welded and powder coated steel table end frames provide strength. Heavy-duty casters provide mobility. Three (3) different work surface heights include seated 29", counter 36" & cafe 42". Tops are available in either 1-1/4" thick high pressure laminate, 1-1/2" thick solid maple butcher block and 1" thick phenolic resin. *Note some maple tops are 1-3/4" thick.*

Optional: Adjustable glides available in lieu of heavy-duty casters. Tables are unassembled and ship flat.

Maker Max Table Standards:

Tops are available in laminate, maple butcher block and phenolic resin
Laminate Worksurface is 1-1/4" thick with PVC edging
Standard Laminates available from Wilsonart, Formica, Pionite and Nevamar
Maple Butcher Block is 1-1/2" thick solid maple hardwood
Phenolic Resin Top is 1" thick phenolic epoxy resin
Top overhangs table frame 1-1/2" on all sides
Frame powder coat available in Platinum Metallic, Black, White and Silver.
Other colors available for 5% upcharge.
Heavy Duty locking casters
* Solid surface and quartz are also available. Contact 3branch for options.



ITEM#	DESCRIPTION	WIDTH	DEPTH	HEIGHT
-------	-------------	-------	-------	--------

maker max tables fixed top - cafe height 42" h
high pressure laminate top w / PVC edge

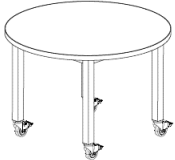
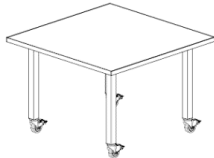
MKX-36-42-LAM		36" dia		42
MKX-42-42-LAM		42" dia		42
MKX-48-42-LAM		48" dia		42
MKX-303042-LAM		30	30	42
MKX-363642-LAM		36	36	42
MKX-424242-LAM		42	42	42
MKX-484842-LAM		48	48	42

maker max tables fixed top - cafe height 42" h
Fixed maple butcher-block Top w / eased edge

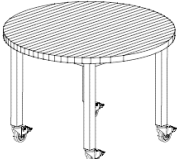
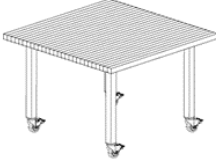
MKX-36-42-BBK (1-3/4" thick)		36" dia		42
MKX-42-42-BBK (1-3/4" thick)		42" dia		42
MKX-48-42-BBK (1-3/4" thick)		48" dia		42
MKX-303042-BBK		30	30	42
MKX-363642-BBK		36	36	42
MKX-424242-BBK (1-3/4" thick)		42	42	42
MKX-484842-BBK (1-3/4" thick)		48	48	42

**2024
Maker Max Table
Specifications**

General Information

Maker Max Tables are durable, functional work tables for crafting and creating in program spaces. Welded and powder coated steel table end frames provide strength. Heavy-duty casters provide mobility. Three (3) different work surface heights include seated 29", counter 36" & cafe 42". Tops are available in either 1-1/4" thick high pressure laminate, 1-1/2" thick solid maple butcher block and 1" thick phenolic resin. *Note some maple tops are 1-3/4" thick.*

Optional: Adjustable glides available in lieu of heavy-duty casters. Tables are unassembled and ship flat.

Maker Max Table Standards:

Tops are available in laminate, maple butcher block and phenolic resin
 Laminate Worksurface is 1-1/4" thick with PVC edging
 Standard Laminates available from Wilsonart, Formica, Pionite and Nevamar
 Maple Butcher Block is 1-1/2" thick solid maple hardwood
 Phenolic Resin Top is 1" thick phenolic epoxy resin
 Top overhangs table frame 1-1/2" on all sides
 Frame powder coat available in Platinum Metallic, Black, White and Silver.
 Other colors available for 5% upcharge.
 Heavy Duty locking casters
 * Solid surface and quartz are also available. Contact 3branch for options.

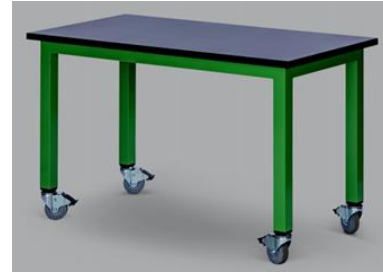

ITEM#	DESCRIPTION	WIDTH	DEPTH	HEIGHT
-------	-------------	-------	-------	--------

maker max tables fixed top - seated height 29" h
phenolic resin top

MKX-482429-RSN		48	24	29
MKX-483029-RSN		48	30	29
MKX-602429-RSN		60	24	29
MKX-603029-RSN		60	30	29
MKX-722429-RSN		72	24	29
MKX-723029-RSN		72	30	29

maker max tables fixed top - Counter height 36" h
phenolic resin top

MKX-482436-RSN		48	24	36
MKX-483036-RSN		48	30	36
MKX-602436-RSN		60	24	36
MKX-603036-RSN		60	30	36
MKX-722436-RSN		72	24	36
MKX-723036-RSN		72	30	36