

ASSEMBLY INSTRUCTIONS

REV #	REVISION DESCRIPTION	DATE
1	ADDED STABILITY NOTE	05.14.24

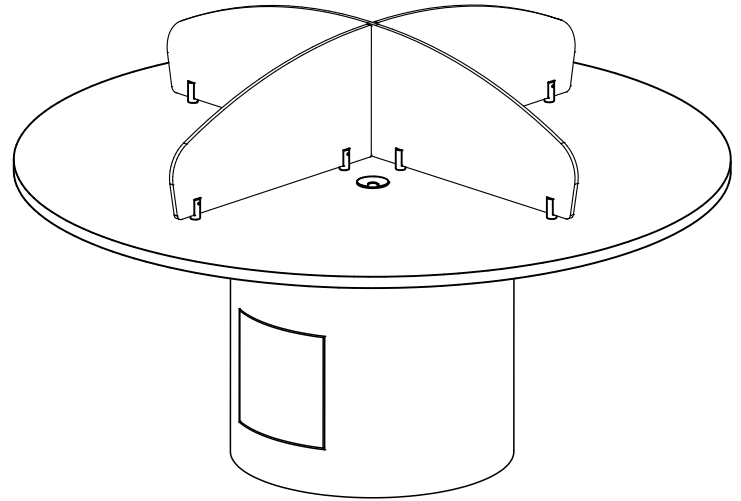

3D MODEL- ASSEMBLED TABLE

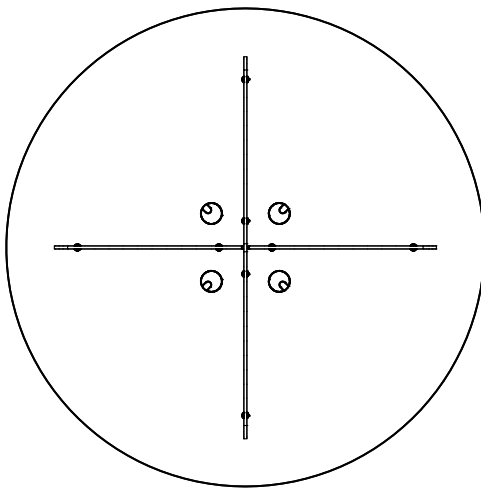

PLAN VIEW- ASSEMBLED TABLE

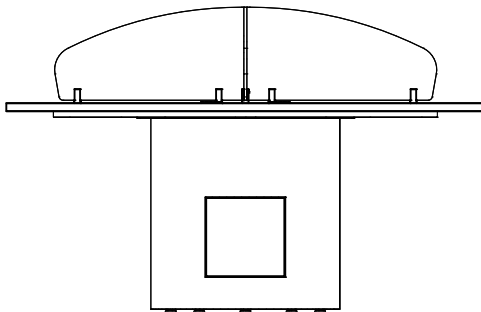

SIDE VIEW- ASSEMBLED TABLE

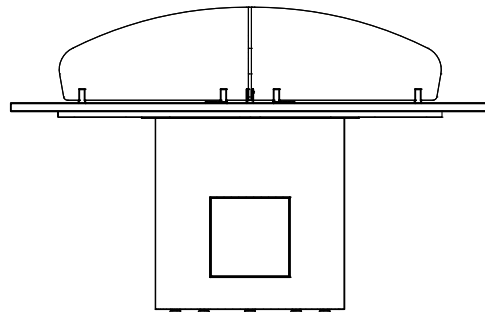

END VIEW- ASSEMBLED TABLE

KURVE COLLECTION

3branch
product design solutions

P 847.291.3900
F 847.291.3901
www.3branch.com

DESCRIPTION: ROUND COMPUTER TABLE
W/CYLINDER BASE & TOP DIVIDERS
ASSEMBLY INSTRUCTIONS

DATE: 07.08.21

DRAWING #KU-CT-60-26-CYB-ATD-ASSEMBLY-01

REV # 1

SHEET 1 OF 5

PARTS LIST:

TABLE TOP	QTY= 1
SUB-TOP	QTY= 1
BASE CYLINDER	QTY= 1
ACRYLIC TOP DIVIDER PANEL- LONG	QTY= 1
ACRYLIC TOP DIVIDER PANEL- SHORT	QTY= 2

HARDWARE:

LEVELER 5/16"-18 X 1 1/2"L STEM	QTY= 5
SUB-TOP/CYLINDER MOUNTING PLATES	QTY= 4
TOP DIVIDER MOUNTING BRACKETS- FOR 3/8"TH PANEL, 13/16" DIA X 1 3/4"H, STAINLESS STEEL, SATIN FINISH	QTY= 8
#10 X 3/4"L FLAT HEAD PHILLIPS SHEET METAL SCREW (SUB-TOP TO CYLINDER BASE MOUNTING)	QTY= 16
#10 X 1 1/2" FLAT HEAD PHILLIPS SHEET METAL SCREW (TOP PANEL TO SUB-TOP MOUNTING)	QTY= 8
5/16"-18 X 1 1/4"L FLAT HEAD PHILLIPS MACHINE SCREW (BRACKET MOUNTING)	QTY= 8

WIRE MANAGEMENT:

GROMMET & LINER, 2"O.D., 1 9/16" I.D., 1 3/4" BORE, 5/8" X 15/16" SLOT, 5/8" TH, ABS, FINISH TO BE SPECIFIED, DOUG MOCKETT #SG3-XX	QTY= 4
---	--------

TOOLS REQ'D:

POWER DRILL/SCREW GUN
PHILLIPS DRIVERS

NOTES:

*ACRYLIC TOP DIVIDERS MUST BE MOUNTED
TO TOP PANEL PRIOR TO MOUNTING TOP
PANEL TO SUB-TOP!!!

*FOR ADDITIONAL STABILTY, CLIENT CAN ADD
WEIGHT TO THE BOTTOM OF THE BASE CYLINDER.
TYPICALLY, SAND BAGS ARE USED.

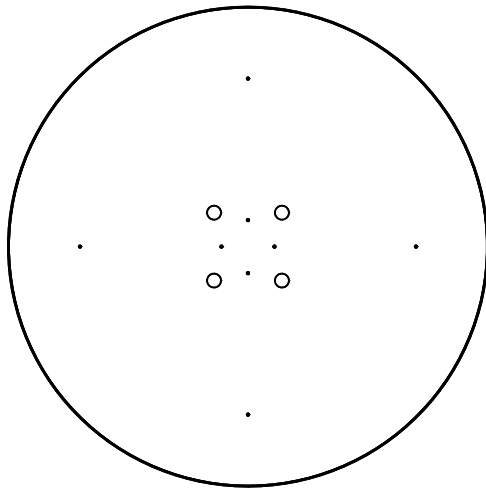

TOP PANEL

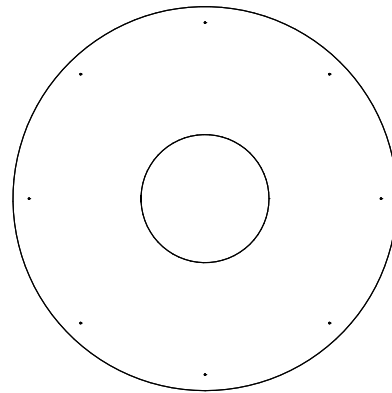

SUB-TOP

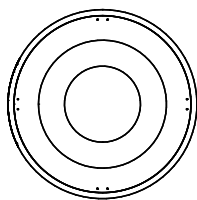

BASE CYLINDER

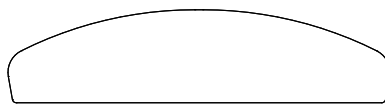

TOP DIVIDER PANEL- LONG

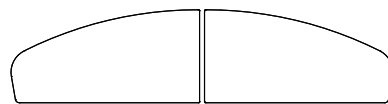

TOP DIVIDER PANEL- SHORT



LEVELERS



SUB-TOP MOUNTING PLATES



PANEL BRACKETS

KURVE COLLECTION

3branch
product design solutions

P 847.291.3900
F 847.291.3901
www.3branch.com

DESCRIPTION: ROUND COMPUTER TABLE
W/CYLINDER BASE & TOP DIVIDERS
ASSEMBLY INSTRUCTIONS

DATE: 07.08.21

DRAWING #KU-CT-60-26-CYB-ATD-ASSEMBLY-01

REV # 1

SHEET 2 OF 5

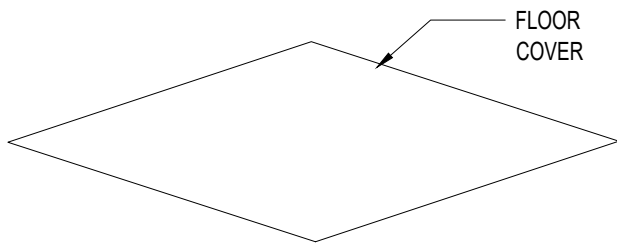

STEP 1
LAY CLEAN COVER ON FLOOR TO PROTECT FLOOR & TABLE PARTS.

STEP 2
REMOVE ALL PACKING MATERIAL FROM TABLE PARTS.
*CAUTION: TWO PEOPLE REQ'D FOR TABLE ASSEMBLY TO AVOID DAMAGE TO TABLE PARTS & PERSONAL INJURY!

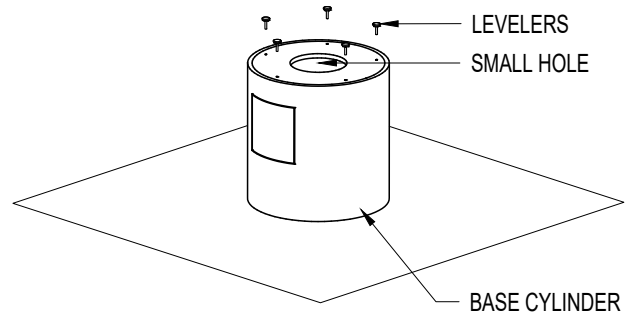

STEP 3
LAY BASE CYLINDER ON COVER WITH LARGE OPENING TURNED DOWN.
*THREADED INSERTS RECESSED INTO BOTTOM PANEL OF BASE CYLINDER FOR LEVELERS WILL BE VISIBLE.
THREAD LEVELERS INTO THREADED INSERTS LOCATED IN BOTTOM OF CYLINDER.

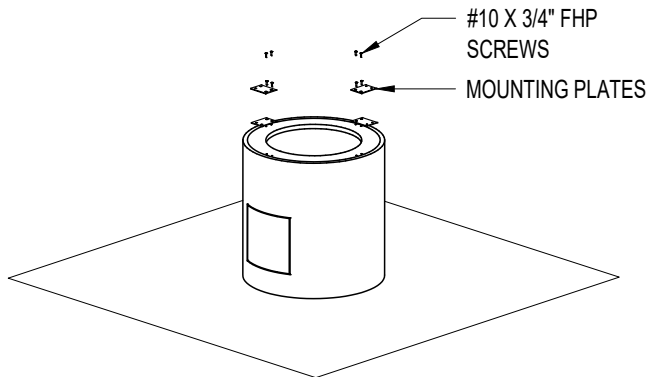

STEP 4
FLIP BASE CYLINDER UPRIGHT ON COVER WITH LEVELERS TURNED DOWN.
MOUNT SUB-TOP MOUNTING PLATES TO TOP OF CYLINDER WITH #12 X 3/4" FLAT HEAD PHILLIPS SCREWS.
*NOTE: PILOT HOLES FOR MOUNTING PLATE SCREWS ARE PRE-DRILLED INTO THE TOP PANEL OF THE BASE CYLINDER.

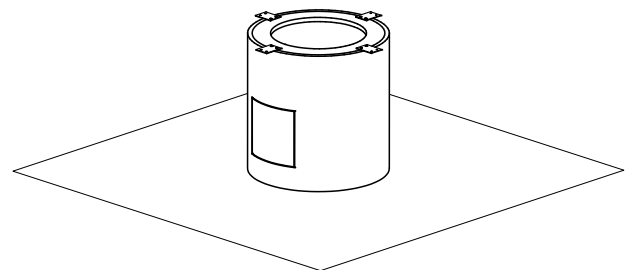

STEP 5
VERIFY THAT SUB-TOP MOUNTING PLATES ARE SECURED TO TOP OF BASE CYLINDER.
REMOVE BASE CYLINDER FROM FLOOR COVER.

KURVE COLLECTION

3branch
product design solutions

P 847.291.3900
F 847.291.3901
www.3branch.com

DESCRIPTION: ROUND COMPUTER TABLE
W/CYLINDER BASE & TOP DIVIDERS
ASSEMBLY INSTRUCTIONS

DATE: 07.08.21

DRAWING #KU-CT-60-26-CYB-ATD-ASSEMBLY-01

REV # 1

SHEET 3 OF 5

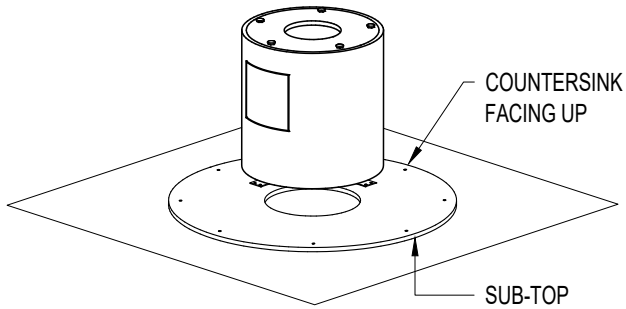

STEP 6

LAY SUB-TOP ON FLOOR COVER.

NOTE: COUNTERSUNK TOP MOUNTING HOLES ARE FACING UP.

FLIP BASE CYLINDER OVER WITH LEVELERS TURNED UP.

CENTER BASE CYLINDER ON SUB-TOP.

MARK & DRILL 1/8" DIA PILOT HOLES IN SUB-TOP FOR MOUNTING SCREWS.

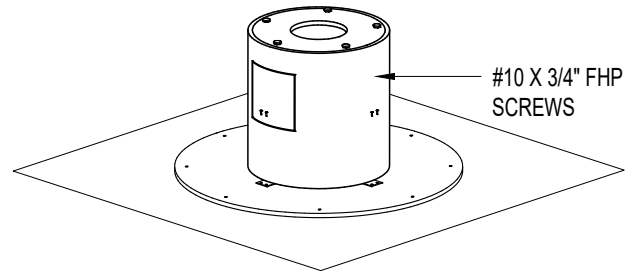

STEP 7

MOUNT BASE CYLINDER TO SUB-TOP WITH #12 X 3/4" FLAT HEAD PHILLIPS SCREWS INSERTED THRU MOUNTING PLATES & THREADING INTO PILOT HOLES PREVIOUSLY DRILLED IN BOTTOM FACE OF SUB-TOP.

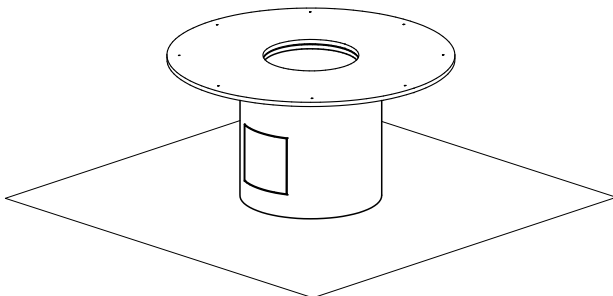

STEP 8

FLIP BASE CYLINDER/SUB-TOP ASSEMBLY UPRIGHT.

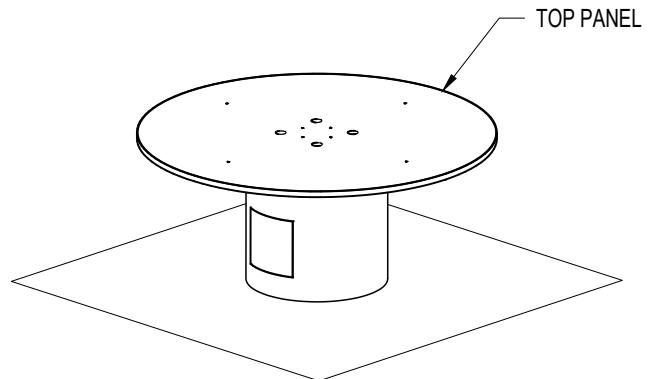

STEP 9

LAY TOP OVER SUB-TOP

*NOTE: RECESSED COUNTERSUNK MOUNTING HOLES FOR TOP DIVIDER BRACKETS NEED TO BE FACING DOWN.

*DO NOT ATTACH TOP DURING THIS STEP!!!

KURVE COLLECTION

3branch
product design solutions

P 847.291.3900

F 847.291.3901

www.3branch.com

DESCRIPTION: ROUND COMPUTER TABLE
W/CYLINDER BASE & TOP DIVIDERS
ASSEMBLY INSTRUCTIONS

DATE: 07.08.21

DRAWING #KU-CT-60-26-CYB-ATD-ASSEMBLY-01

REV # 1

SHEET 4 OF 5

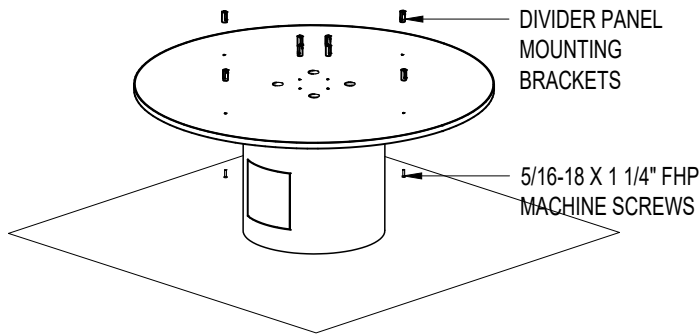

STEP 10

MOUNT TOP DIVIDER BRACKETS TO TOP PANEL WITH 5/16" X 1 1/4" MACHINE SCREWS INSERTED UP THRU COUNTERSUNK HOLES IN TOP PANEL.

*NOTE LEAVE DIVIDER BRACKETS SLIGHTLY LOOSE UNTIL DIVIDER PANEL ARE INSERTED IN THE SLOTS IN THE BRACKETS.

*NOTE: TOP PANEL WILL NEED TO BE MOVED AROUND TO ACCESS HOLES LOCATED @ CENTER OF TOP PANEL. TWO PEOPLE REQ'D TO PREVENT TOP FALLING.

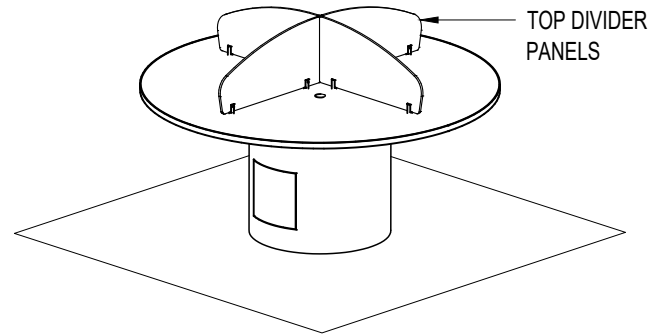

STEP 11

CENTER & INSERT LONG TOP DIVIDER PANEL INTO SLOTS IN BRACKETS. INSERT SHORT TOP DIVIDER PANELS INTO SLOTS IN BRACKETS.

*NOTE: OFFSET SHORT DIVIDER PANELS 1/8" FROM FACE OF LONG DIVIDER PANEL.

TIGHTEN SET SCREWS IN TOP DIVIDER BRACKETS TO SECURE DIVIDER PANELS.

AFTER ALL DIVIDER PANELS HAVE BEEN SECURED, TIGHTEN ALL DIVIDER MOUNTING BRACKET MACHINE SCREWS.

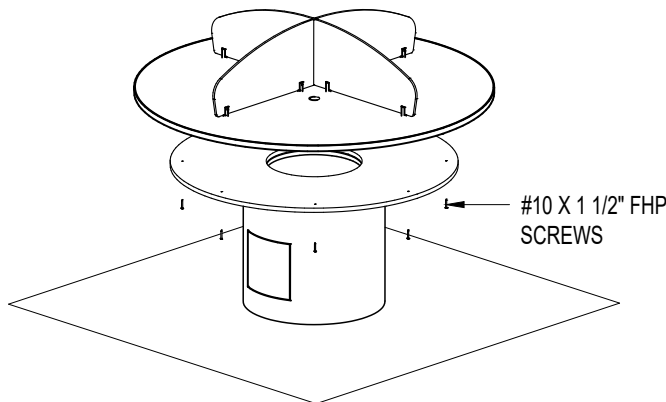

STEP 12

CENTER TOP PANEL ON BASE CYLINDER.

MOUNT TOP PANEL TO SUB-TOP WITH #10 X 1 1/2" FLAT HEAD PHILLIPS SHEET METAL SCREWS.

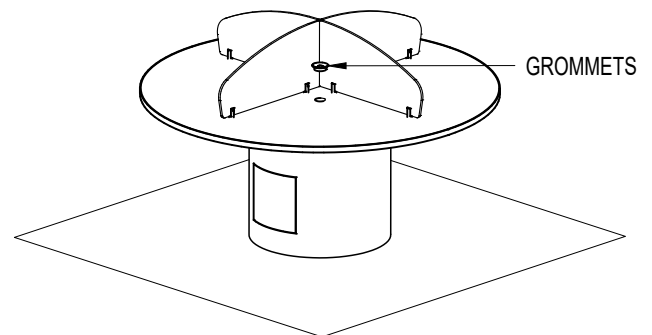

STEP 13

INSTALL GROMMETS IN HOLES LOCATED @ CENTER OF TOP.

LOCATE & LEVEL ASSEMBLED TABLE.

ADD SAND BAG TO BASE THRU ACCESS DOOR.

KURVE COLLECTION

3branch
product design solutions

P 847.291.3900
F 847.291.3901
www.3branch.com

DESCRIPTION: ROUND COMPUTER TABLE
W/CYLINDER BASE & TOP DIVIDERS
ASSEMBLY INSTRUCTIONS

DATE: 07.08.21

DRAWING #KU-CT-60-26-CYB-ATD-ASSEMBLY-01

REV # 0

SHEET 5 OF 5