

REV #	REVISION DESCRIPTION	DATE
1	UPDATED COLUMN LABELS TO NEW CONFIGURATION	06.01.24

MAKER FLEX NESTING ADJUSTABLE HEIGHT TABLE WITH SINGLE HANDLE ASSEMBLY INSTRUCTIONS

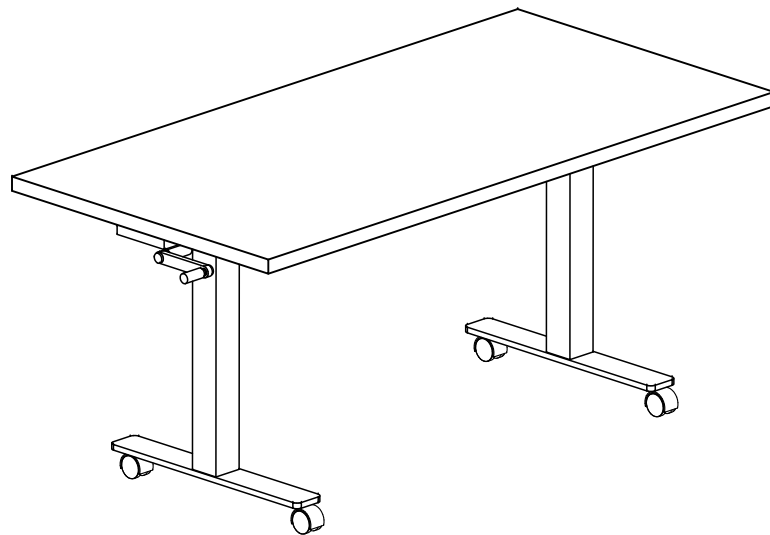

ASSEMBLED TABLE

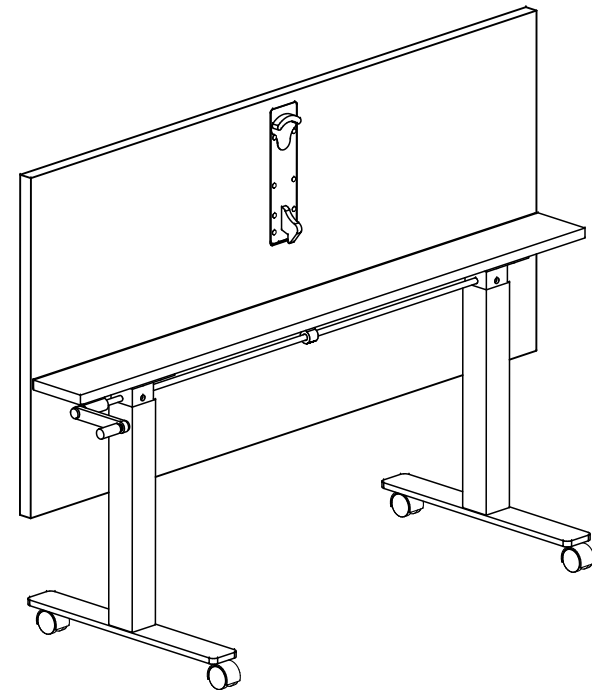

ASSEMBLED TABLE WITH TOP FLIPPED UP FOR STORAGE

PARTS LIST:

TABLE TOP (PLASTIC LAMINATE OR SOLID WOOD BUTCHER BLOCK)	QTY= 1
BASE COLUMN ASSEMBLIES "A" ADT HT (CW)	QTY= 1
BASE COLUMN ASSEMBLIES "B" ADT HT (CCW)	QTY= 1
BASE MAIN BARS 22"L	QTY= 2
BASE MOUNTING PLATES	QTY= 2
NESTER EXTRUSION ASSEMBLY	QTY= 1
NESTER HANDLE ASSEMBLY	QTY= 1
NESTER LID STAY ASSEMBLY	QTY= 1
HAND CRANK DRIVE ROD	QTY= 1
HAND CRANK DRIVE ROD GUIDE	QTY= 1
HAND CRANK HANDLE ASSEMBLY	QTY= 1

HARDWARE:

PREMIUM CASTERS, 5/16"-18 X 1/2"L STEM	QTY= 4
SCREW M8 X 35MM FHCS HEX DRIVE	QTY= 8
SCREW M8 X 25MM FHCS HEX DRIVE	QTY= 8
SCREW #12-24 X 3/4" PPH TYPE F	QTY= 18
SCREW #12 X 1"L PPH	QTY= 19
SCREW #8 X 1/2"L PPH	QTY= 4
SCREW #12 X 3/4" PPH	QTY= 2

WIRE MANAGMENT:

N/A	QTY= 0
-----	--------

TOOLS REQ'D:

- 5MM HEX HEAD DRIVER/BIT ("T" BASE ASSEMBLY)
- PHILLIPS SCREWDRIVERS/BITS
- PENCIL
- SCRATCH AWL

NOTE:

WORKURFACE HEIGHT ADJUSTABLE FROM 26" TO 40"

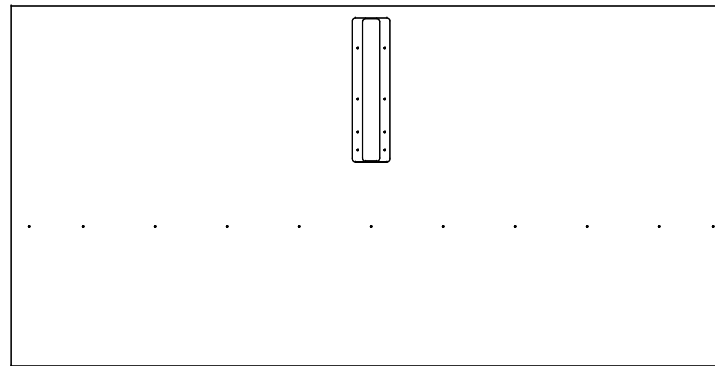

TOP PANEL (BOTTOM VIEW)

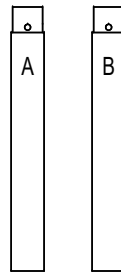

BASE COLUMNS

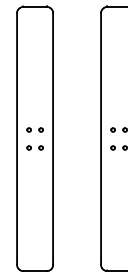

BASE MAIN BARS

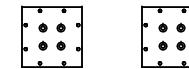

BASE MOUNTING PLATES



CASTERS



HAND CRANK DRIVE ROD



NESTER EXTRUSION ASSEMBLY

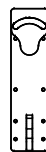

NESTER HANDLE ASSEMBLY



NESTER LID STAY ASSEMBLY

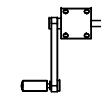

HAND CRANK HANDLE ASSEMBLY



HAND CRANK DRIVE ROD GUIDE

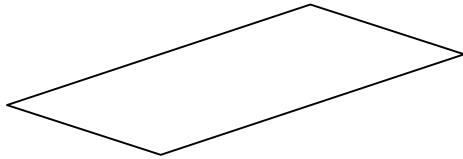

STEP 1
LAY CLEAN COVER ON FLOOR TO PROTECT FLOOR & PARTS.

STEP 2
REMOVE ALL PACKING MATERIAL FROM TABLE BASE PARTS & TOP.
*CAUTION: TWO PEOPLE REQ'D FOR TABLE ASSEMBLY TO AVOID DAMAGE TO TABLE PARTS & PERSONAL INJURY!

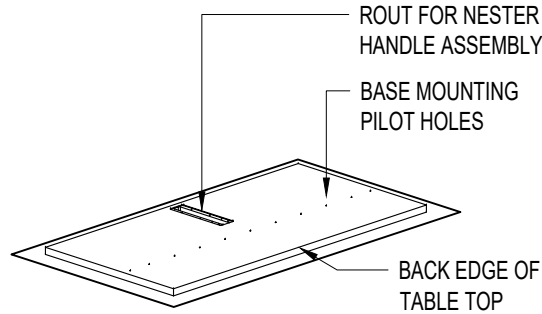

STEP 3
LAY TOP PANEL ON COVER WITH GOOD FACE TURNED DOWN.
*ROUTED RECESS FOR NESTER HANDLE ASSEMBLY & PILOT HOLES FOR MOUNTING BASE WILL BE VISIBLE.

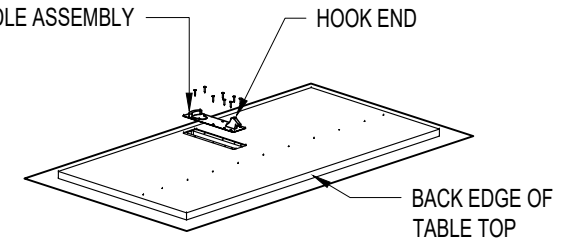

STEP 4
SET HANDLE ASSEMBLY OVER ROUTED RECESS IN TOP PANEL.
*NOTE: HOOK END TO FACE TOWARD CENTER OF TABLE. ALIGN HOLES IN HANDLE ASSEMBLY PLATE WITH PILOT HOLES IN TOP.
CLIP ZIP TIES
PLACE HANDLE ASSEMBLY INTO ROUTED RECESS & SECURE TO TOP PANEL WITH EIGHT #12 X 1" PPH SCREWS.

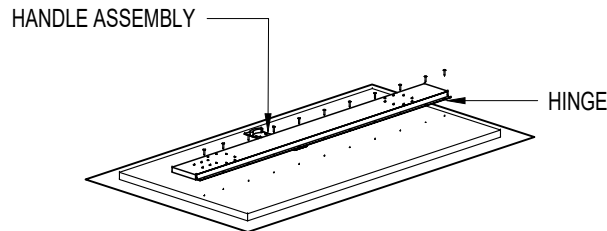

STEP 5
PLACE NESTER EXTRUSION ASSEMBLY ON TOP PANEL & ALIGN THE ROW OF MOUNTING HOLES IN THE HINGE WITH THE ROW OF PRE-DRILLED PILOT HOLES IN THE TOP PANEL.
*NOTE: ORIENTATE THE NESTER EXTRUSION ASSEMBLY SO THAT THE HINGE SIDE IS AWAY FROM THE HANDLE ASSEMBLY. SECURE HINGE TO TOP WITH ELEVEN #12 X 1" PPH SCREWS.

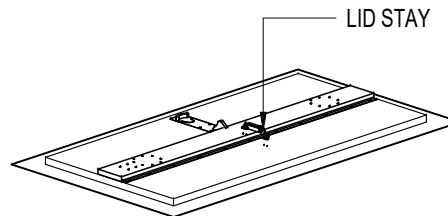

STEP 6A
POSITION LID STAY AS SHOWN & ALIGN THE TWO FRONT HOLES IN LID STAY WITH THE TWO HOLES IN THE NESTER EXTRUSION. NOTE: ENSURE THAT THE LID STAY IS 90°/PERPENDICULAR TO THE NESTER EXTRUSION.
MARK THE TWO HOLE LOCATIONS ON THE FACE OF THE TOP WITH A PENCIL.
PUNCH THE TWO HOLE CENTERS WITH A SCRATCH AWL TO PREVENT DRILL BIT MOVEMENT WHILE DRILLING.
DRILL TWO 1/8" DIA X 3/8" DEEP PILOT HOLES.

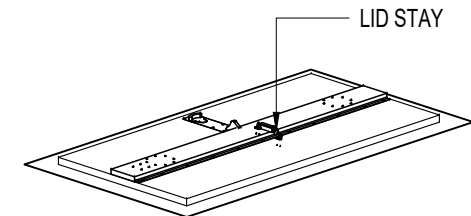

STEP 6B
IF THERE ARE NO PRE-DRILLED HOLES IN THE NESTER EXTRUSION, ALIGN THE NOTCHES IN THE LID STAY WITH THE CENTER OF THE TOP, SLIDE THE TEMPLATE UP TIGHT TO THE HINGE. MARK ALL FOUR HOLE LOCATIONS & DRILL FOUR 1/8" DIA X 3/8" DEEP PILOT HOLES.

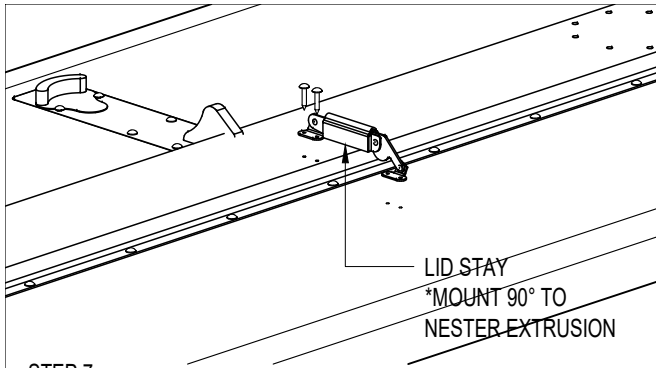

STEP 7

POSITION LID STAY OVER NESTER EXTRUSION & ALIGN THE TWO HOLES IN THE LID STAY WITH THE TWO HOLES IN THE NESTER EXTRUSION.
 *ENSURE THAT LID STAY IS 90°/PERPENDICULAR TO NESTER EXTRUSION.
 SECURE THE LID STAY TO THE NESTER EXTRUSION WITH TWO #12 X 1/2" SCREWS.

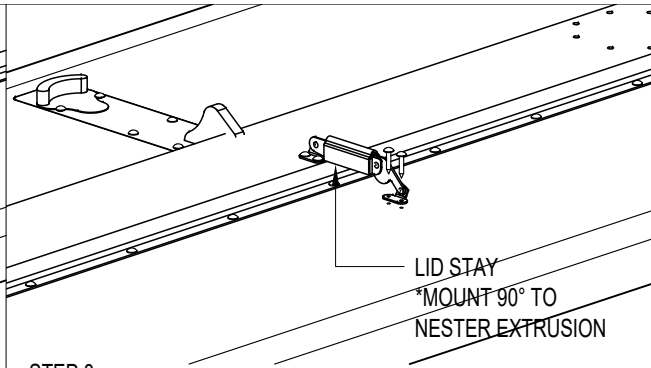

STEP 8

SECURE LID STAY TO TABLE TOP WITH TWO #8 X 1/2" SCREWS.
 *NOTE: LID STAY SPRING MAY NEED TO COMPRESS AS SCREWS ARE INSTALLED IN ORDER FOR HOLES TO ALIGN. THIS IS NORMAL AND REQUIRED FOR PROPER OPERATION. THE LID STAY MAY HAVE A PLASTIC SPACER PRE-INSTALLED FOR EASE OF INSTALLATION. THE SPACER SHOULD FALL OUT AND CAN BE DISCARDED.

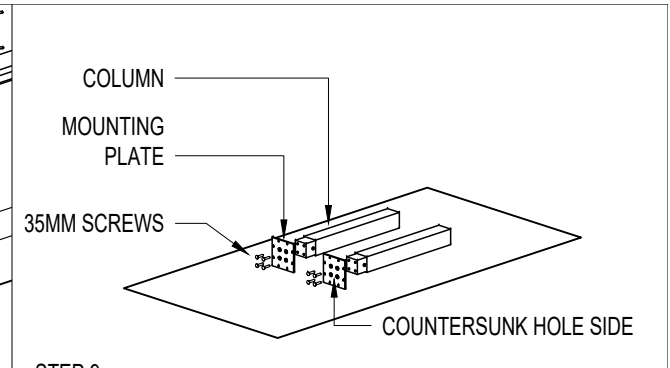

STEP 9

LAY COLUMN BASE PARTS OUT ON CLEAN COVER ON FLOOR. ALIGN THE FOUR HOLES IN THE MOUNTING PLATE WITH THE FOUR TAPPED HOLES LOCATED IN THE TOP OF THE COLUMN.
 *NOTE: COUNTERSUNK SIDE OF HOLES IN PLATE TO FACE OUT. INSERT THE M8 X 35MM SCREWS THRU THE HOLES IN THE MOUNTING PLATE AND THREAD INTO THE TAPPED HOLES IN THE COLUMN (4/END BASE).
 USE A 5MM HEX DRIVE WRENCH TO TIGHTEN THE SCREWS TO 15 FT/LBS OF FORCE.

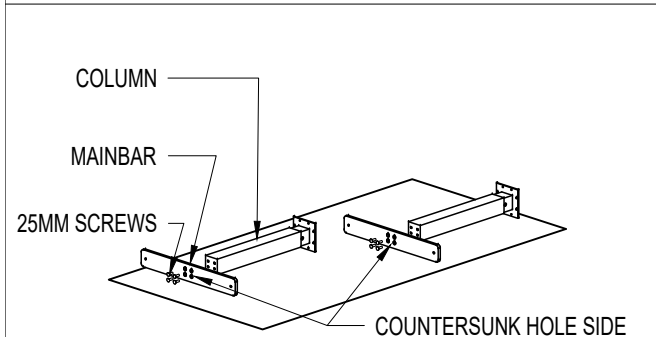

STEP 10

ALIGN THE FOUR HOLES IN THE MAINBAR WITH THE FOUR TAPPED HOLES LOCATED IN THE BOTTOM OF THE COLUMN.
 *NOTE: COUNTERSUNK SIDE OF HOLES IN MAINBAR TO FACE OUT. INSERT THE M8 X 25MM SCREWS THRU THE HOLES IN THE MAINBAR AND THREAD INTO THE TAPPED HOLES IN THE COLUMN (4/END BASE).
 USE A 5MM HEX DRIVE WRENCH TO TIGHTEN THE SCREWS TO 15 FT/LBS OF FORCE.

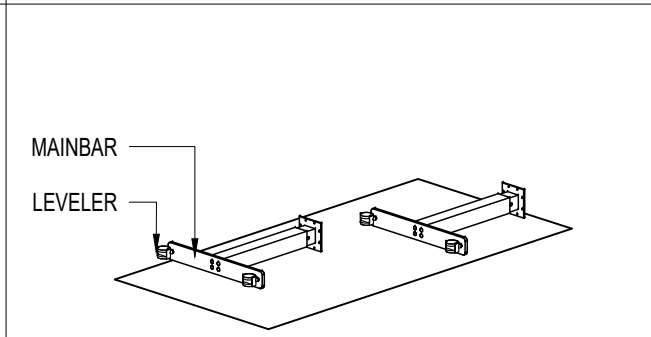

STEP 11

MOUNT THE LEVELERS OR CASTERS TO THE MAINBAR BY TIGHTENING THE THREADED STEMS INTO THE THREADED INSERTS WELDED TO THE BOTTOM OF THE MAINBAR.

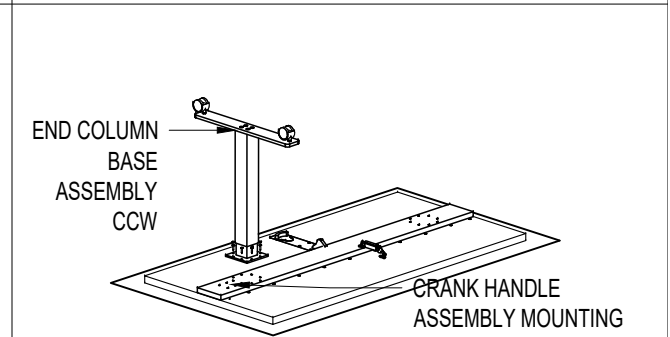

STEP 12:

LOCATE END COLUMN BASE ASSEMBLY CCW ON THE END OF THE NESTER EXTRUSION ASSEMBLY WHERE THE CRANK HANDLE WILL BE MOUNTED.
 ALIGN THE MOUNTING HOLES IN THE MOUNTING PLATE WITH THE HOLES IN THE NESTER EXTRUSION ASSEMBLY.
 SECURE THE COLUMN ASSEMBLY TO THE NESTER EXTRUSION WITH EIGHT #12-24 X 3/4" MACHINE SCREWS.
***TORQUE SCREWS TO 3-5 FT/LBS. DO NOT OVERTIGHTEN.**

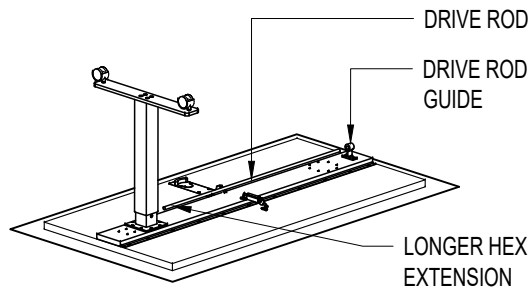

STEP 13:
 SLIDE END OF DRIVE ROD WITH LONGER HEX EXTENSION INTO HOLE LOCATED AT THE TOP OF CCW END COLUMN BASE ASSEMBLY.
 SLIDE DRIVE ROD GUIDE ONTO DRIVE ROD.

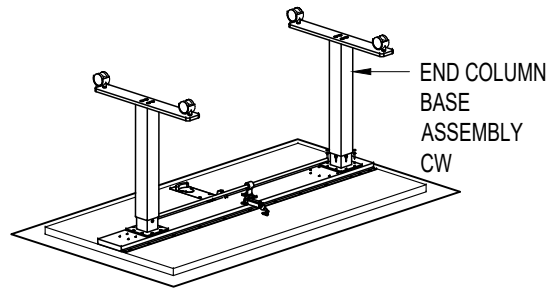

STEP 14:
 SLIDE CW END COLUMN BASE ASSEMBLY ONTO THE OPPOSITE END OF THE DRIVE ROD.
 ALIGN THE MOUNTING HOLES IN THE MOUNTING PLATE WITH THE HOLES IN THE NESTER EXTRUSION ASSEMBLY.
 SECURE THE COLUMN ASSEMBLY TO THE NESTER EXTRUSION WITH EIGHT #12-24 X 3/4" MACHINE SCREWS.

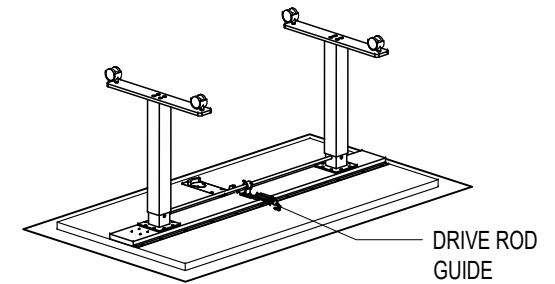

STEP 15:
 ALIGN HOLES IN DRIVE ROD GUIDE WITH HOLES LOCATED AT THE CENTER OF THE NESTER EXTRUSION ASSEMBLY.
 ATTACH THE DRIVE ROD GUIDE TO THE NESTER EXTRUSION ASSEMBLY WITH TWO #12-24 X 3/4" SCREWS.

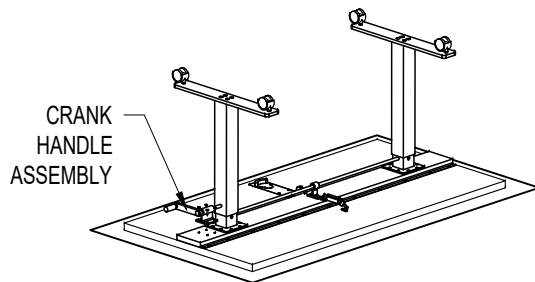

STEP 16:
 SLIDE HAND CRANK HANDLE ASSEMBLY INTO CCW END BASE. ALIGN HOLES IN HAND CRANK HANDLE ASSEMBLY WITH HOLES LOCATED AT THE END OF THE NESTER EXTRUSION ASSEMBLY. ATTACH THE HAND CRANK ASSEMBLY TO THE NESTER EXTRUSION ASSEMBLY WITH FOUR #12-24 X 3/4" SCREWS.

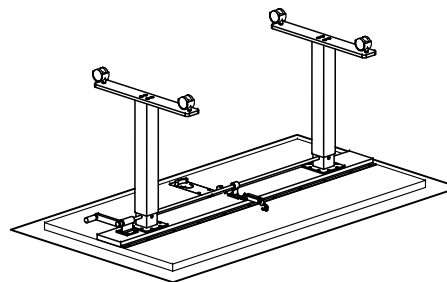

STEP 17:
 CHECK ALL SCREWS FOR TIGHTNESS.
 TURN ASSEMBLED TABLE UPRIGHT.
 *CAUTION: TWO PEOPLE REQ'D TO TURN TABLE OVER TO AVOID DAMAGE TO TABLE PARTS & PERSONAL INJURY!
 *CAUTION: DO NOT PIVOT ON BASE TO AVOID DAMAGE TO TABLE BASE!

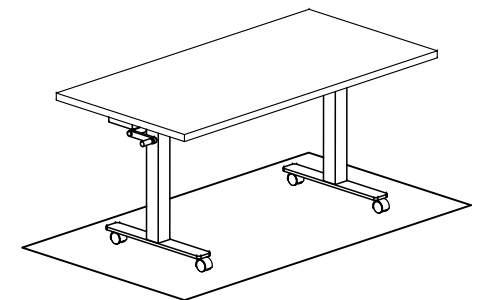

STEP 18:
 PULL HAND CRANK HANDLE OUT TO RAISE & LOWER TOP TO DESIRED HEIGHT.
 PUSH HAND CRANK HANDLE IN TO STORE BELOW TOP.
 TURN HAND CRANK HANDLE CLOCKWISE TO RAISE TABLE.
 TURN HAND CRANK HANDLE COUNTER CLOCKWISE TO LOWER TABLE.
 PULL ON NESTER HANDLE ASSEMBLY HANDLE TO RELEASE TOP AND PIVOT TOP DOWN FOR STORAGE.