

magstak™ counter display

assembly instructions

- 1 Remove items from packaging and check packing slip for proper contents and quantity.

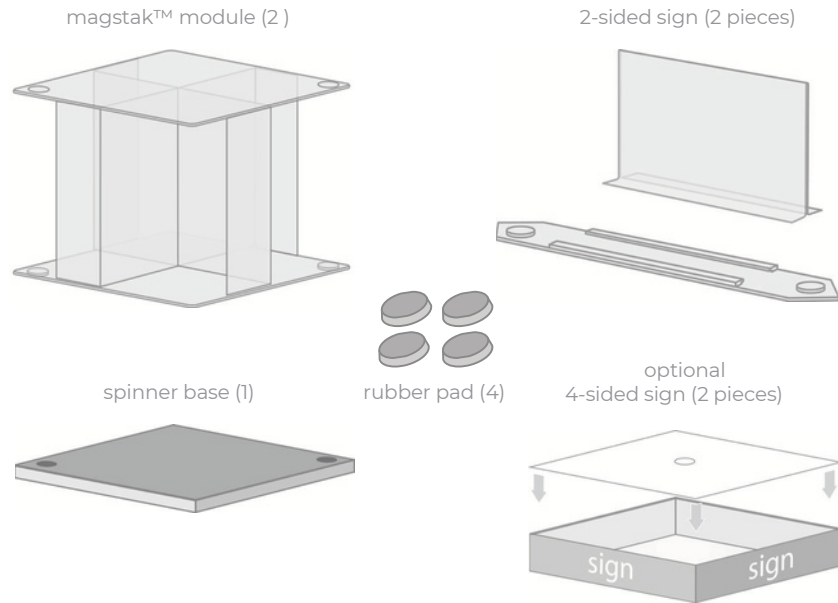

- 2 Attach rubber pads on metal plate on the bottom of the spinner base using the smallest holes as placement markers.

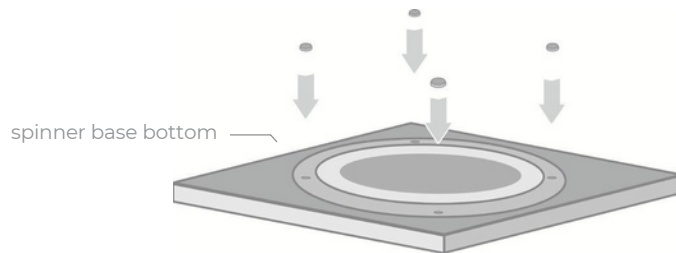

- 3 Stack one magstak™ module on top of the spinner base using the alignment disks that set into alignment ports as shown below.

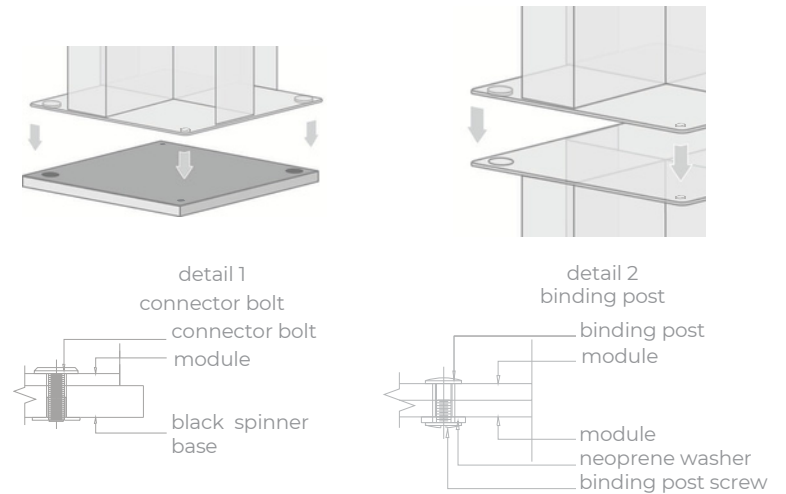

- 4 Optional: connect bottom module to spinner base using connector bolts (see detail 1). Stack second module in same fashion and connect the two modules using the binding post, neoprene washer and binding screw (see detail 2) to ensure a secure and stable fit. Do not over tighten!

- 5 See optional magstak™ signage assembly instruction on reverse/page 2.

optional magstak™ signage

assembly instructions

1 You can use one standard 8.5 x 11 inch piece of paper to satisfy all of your signage needs. See options below.



2 Insert your printed signage into appropriate holder as shown below.

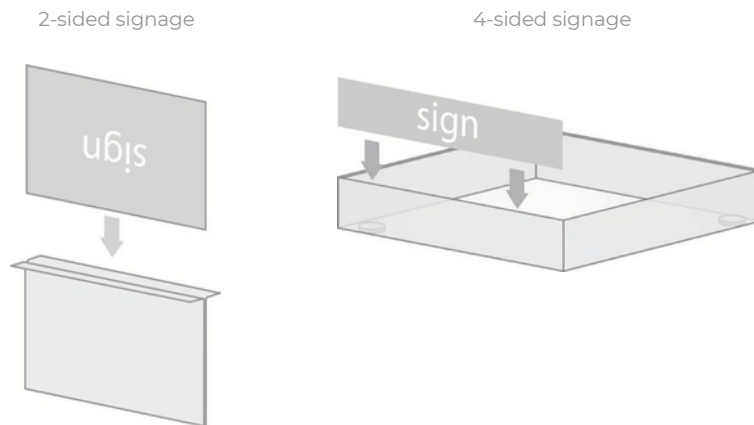

3 Combine signage components.

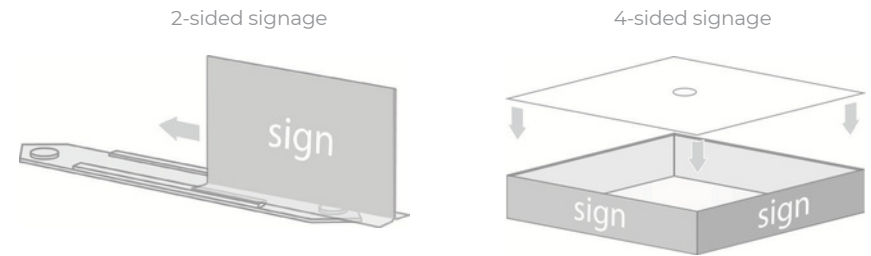

4 Place signage on top-most magstak™ module, making sure to connect alignment discs with alignment ports.

