

**PARTS LIST:**

CASTER BASE PANEL QTY= 1

**HARDWARE:**

CASTER W/MOUNTING PLATE QTY= 4

#12 X 3/4"L ROUND HEAD PHILLIPS SHEET QTY= 16

METAL SCREW (CASTER TO BASE PANEL)

#8 X 1 1/4"L FLAT HEAD PHILLIPS WOOD QTY= 7

SCREW (CASTER BASE PANEL TO TABLE)

**TOOLS REQ'D:**

POWER DRILL/SCREW GUN, PHILLIPS DRIVERS

**NOTE:**

\*CASTER BASE SHIPS ASSEMBLED WITH CASTERS ALREADY MOUNTED.

\*CAUTION: TWO PEOPLE REQ'D FOR CASTER BASE MOUNTING TO AVOID DAMAGE TO PARTS & PERSONAL INJURY!

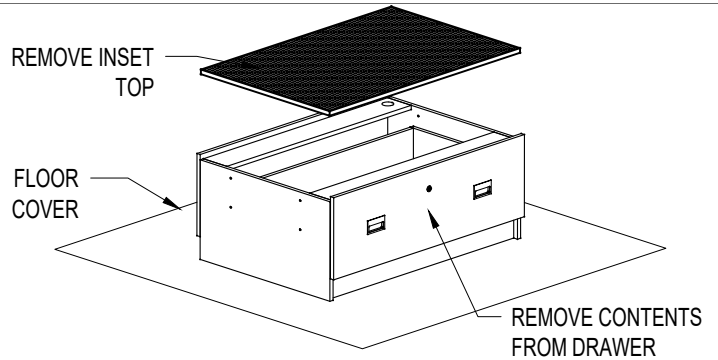

**STEP 1**

NOTE: REMOVE ALL ITEMS FROM DRAWER IF TABLE HAS BEEN IN USE. REMOVE INSET TOP IF ALREADY INSTALLED. END PANELS OR STORAGE BINS CAN REMAIN ATTACHED IF ALREADY ATTACHED.

**STEP 2**

LAY CLEAN COVER ON FLOOR TO PROTECT FLOOR & TABLE PARTS.

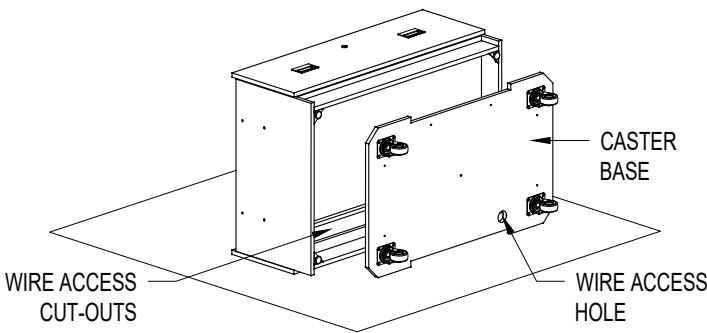

**STEP 3**

CAREFULLY LAY TABLE ON ITS BACK.

**STEP 4**

STAND CASTER BASE ON ITS SIDE. BASE SHIPS WITH CASTERS ATTACHED. NOTE: ORIENTATE THE WIRE ACCESS HOLE IN CASTER BASE PANEL DOWN TOWARD FLOOR TO ALIGN WITH CUT-OUTS IN BOTTOM OF TABLE.

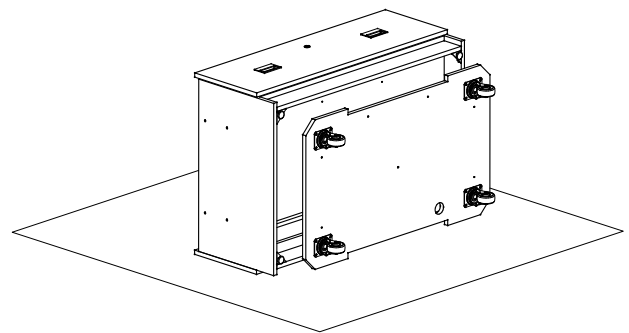

**STEP 5**

CENTER CASTER BASE ON BOTTOM PANEL. NOTE: MAKE SURE TO ORIENTATE THE WIRE ACCESS HOLE IN CASTER BASE PANEL TOWARD THE BACK OF THE TABLE. MARK PILOT HOLE LOCATIONS FOR THE CASTER BASE MOUNTING SCREWS ON THE FACE OF THE BOTTOM PANEL. DRILL 1/8" DIA X 3/4" DEEP PILOT HOLES.

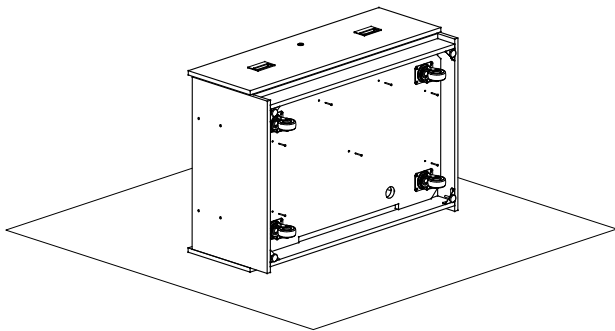

**STEP 6**

MOUNT CASTER BASE TO BOTTOM FACE OF TABLE BOTTOM PANEL WITH #8 X 1 1/4" FLAT HEAD PHILLIPS WOOD SCREWS.

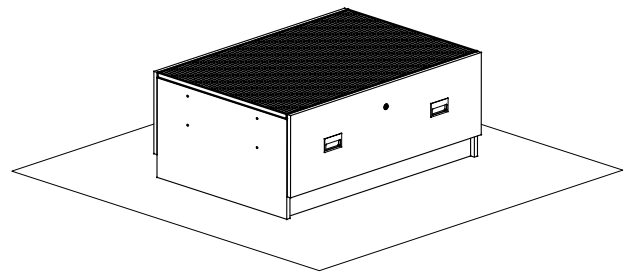

**STEP 7**

ROTATE TABLE ONTO THE CASTERS ATTACH END PANELS OR STORAGE BINS AS SPECIFIED INSTALL REVERSIBLE TOP ROLL TABLE INTO POSITION

DISCOVERY COLLECTION

**3branch**  
product design solutions

P 847.291.3900  
F 847.291.3901  
www.3branch.com

DESCRIPTION: **CASTER BASE MOUNTING INSTRUCTIONS**