

**2024
Maker Flex Table
Specifications**

General Information

Maker Flex Tables are durable, functional work tables allowing for flexibility in program spaces. Powder coated steel table bases provide strength and casters provide mobility. Choose either a high-pressure laminate or maple butcher block top, available at a fixed height or as height-adjustable. Nesting/flip top also available. Optional: adjustable glides in lieu of casters. Tables are unassembled and ship flat.

Maker Flex™ Table Fixed Height Standards:

Fixed Worksurface 29" or 36" above finish floor (AFF) with casters
 Worksurface is 1-1/4" thick MDF with standard laminate surface & edge banding
 Standard Laminates are available from Wilsonart, Formica, Pionite and Nevamar
 Powder coated base available in Platinum Metallic, Black, White and Silver
 Other colors available for 5% upcharge
 Locking casters



shown with platinum metallic powder coated base

ITEM#	DESCRIPTION	WIDTH	DEPTH	HEIGHT
-------	-------------	-------	-------	--------

maker flex tables HP Laminate top - seated height 29"h

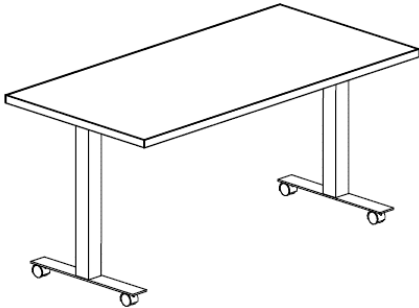
MF-482429-FIXT-LAM-CAS		48	24	29
MF-483029-FIXT-LAM-CAS		48	30	29
MF-483629-FIXT-LAM-CAS		48	36	29
MF-542429-FIXT-LAM-CAS		54	24	29
MF-543029-FIXT-LAM-CAS		54	30	29
MF-543629-FIXT-LAM-CAS		54	36	29
MF-602429-FIXT-LAM-CAS		60	24	29
MF-603029-FIXT-LAM-CAS		60	30	29
MF-603629-FIXT-LAM-CAS		60	36	29
MF-662429-FIXT-LAM-CAS		66	24	29
MF-663029-FIXT-LAM-CAS		66	30	29
MF-663629-FIXT-LAM-CAS		66	36	29
MF-722429-FIXT-LAM-CAS		72	24	29
MF-723029-FIXT-LAM-CAS		72	30	29
MF-723629-FIXT-LAM-CAS	72	36	29	

Fixed seated height (29" AFF) / caster base

maker flex tables HP Laminate top - counter height 36"h

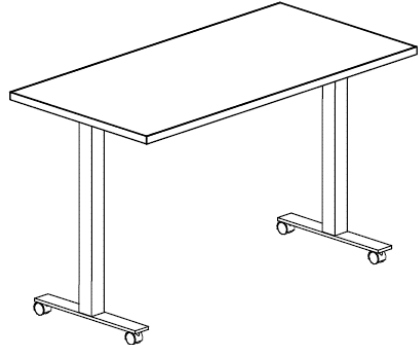
MF-482436-FIXT-LAM-CAS		48	24	36
MF-483036-FIXT-LAM-CAS		48	30	36
MF-483636-FIXT-LAM-CAS		48	36	36
MF-542436-FIXT-LAM-CAS		54	24	36
MF-543036-FIXT-LAM-CAS		54	30	36
MF-543636-FIXT-LAM-CAS		54	36	36
MF-602436-FIXT-LAM-CAS		60	24	36
MF-603036-FIXT-LAM-CAS		60	30	36
MF-603636-FIXT-LAM-CAS		60	36	36
MF-662436-FIXT-LAM-CAS		66	24	36
MF-663036-FIXT-LAM-CAS		66	30	36
MF-663636-FIXT-LAM-CAS		66	36	36
MF-722436-FIXT-LAM-CAS		72	24	36
MF-723036-FIXT-LAM-CAS		72	30	36
MF-723636-FIXT-LAM-CAS	72	36	36	

Fixed counter height (36" AFF) / caster base

**2024
Maker Flex Table
Specifications**

General Information

Maker Flex Tables are durable, functional work tables allowing for flexibility in program spaces. Powder coated steel table bases provide strength and casters provide mobility. Choose either a high-pressure laminate or maple butcher block top, available at a fixed height or as height-adjustable. Nesting/flip top also available. Optional: adjustable glides in lieu of casters. Tables are unassembled and ship flat.

Maker Flex™ Nesting / Flip Top - Fixed Height Standards:

Nesting / Flip top Worksurface is 29" or 36" above finish floor (AFF) with casters
 Worksurface is 1-1/4" thick MDF with standard laminate surface & edge banding
 Standard Laminates are available from Wilsonart, Formica, Pionite and Nevamar
 Powder coated base available in Platinum Metallic, Black, White and Silver
 Other colors available for 5% upcharge
 Locking casters
 Tables that are 72" wide or 36" deep have two (2) release handles



shown with platinum metallic powder coated base



24" deep storage depth = 18" + (# tables - 1) x 7.25"
 30" deep storage depth = 22" + (# tables - 1) x 7.25"
 36" deep storage depth = 26" + (# tables - 1) x 7.25"

ITEM#	DESCRIPTION	WIDTH	DEPTH	HEIGHT
-------	-------------	-------	-------	--------

maker flex tables HP Laminate top - nesting / seated height 29"h

- MF-482429-NEST-FIXT-LAM-CAS
- MF-483029-NEST-FIXT-LAM-CAS
- MF-483629-NEST-FIXT-LAM-CAS
- MF-542429-NEST-FIXT-LAM-CAS
- MF-543029-NEST-FIXT-LAM-CAS
- MF-543629-NEST-FIXT-LAM-CAS
- MF-602429-NEST-FIXT-LAM-CAS
- MF-603029-NEST-FIXT-LAM-CAS
- MF-603629-NEST-FIXT-LAM-CAS
- MF-662429-NEST-FIXT-LAM-CAS
- MF-663029-NEST-FIXT-LAM-CAS
- MF-663629-NEST-FIXT-LAM-CAS
- MF-722429-NEST-FIXT-LAM-CAS
- MF-723029-NEST-FIXT-LAM-CAS
- MF-723629-NEST-FIXT-LAM-CAS

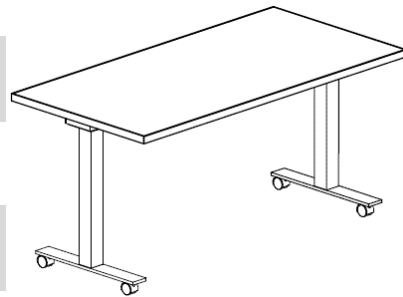

48	24	29
48	30	29
48	36	29
54	24	29
54	30	29
54	36	29
60	24	29
60	30	29
60	36	29
66	24	29
66	30	29
66	36	29
72	24	29
72	30	29
72	36	29

Nesting - Fixed seated height (29" AFF) / caster base

maker flex tables HP Laminate top - nesting / counter height 36"h

- MF-482436-NEST-FIXT-LAM-CAS
- MF-483036-NEST-FIXT-LAM-CAS
- MF-483636-NEST-FIXT-LAM-CAS
- MF-542436-NEST-FIXT-LAM-CAS
- MF-543036-NEST-FIXT-LAM-CAS
- MF-543636-NEST-FIXT-LAM-CAS
- MF-602436-NEST-FIXT-LAM-CAS
- MF-603036-NEST-FIXT-LAM-CAS
- MF-603636-NEST-FIXT-LAM-CAS
- MF-662436-NEST-FIXT-LAM-CAS
- MF-663036-NEST-FIXT-LAM-CAS
- MF-663636-NEST-FIXT-LAM-CAS
- MF-722436-NEST-FIXT-LAM-CAS
- MF-723036-NEST-FIXT-LAM-CAS
- MF-723636-NEST-FIXT-LAM-CAS

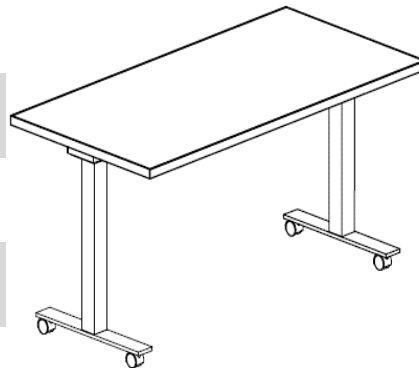

48	24	36
48	30	36
48	36	36
54	24	36
54	30	36
54	36	36
60	24	36
60	30	36
60	36	36
66	24	36
66	30	36
66	36	36
72	24	36
72	30	36
72	36	36

Nesting - Fixed counter height (36" AFF) / caster base

**2024
Maker Flex Table
Specifications**

General Information

Maker Flex Tables are durable, functional work tables allowing for flexibility in program spaces. Powder coated steel table bases provide strength and casters provide mobility. Choose either a high-pressure laminate or maple butcher block top, available at a fixed height or as height-adjustable. Nesting/flip top also available. Optional: adjustable glides in lieu of casters. Tables are unassembled and ship flat.

Maker Flex™ Table Height-adjustable Standards:

Height-adjustable Worksurface range is 29" - 47" above finish floor (AFF) with casters

Retractable hand crank located on patron side of table

Worksurface is 1-1/4" thick MDF with standard laminate surface & edge banding

Standard Laminates are available from Wilsonart, Formica, Pionite and Nevamar

Powder coated base available in Platinum Metallic, Black, White and Silver

Other colors available for 5% upcharge

Locking casters



shown with platinum metallic powder coated base

ITEM#	DESCRIPTION	WIDTH	DEPTH	HEIGHT
-------	-------------	-------	-------	--------

maker flex tables HP Laminate top - adjustable height 29"-47"h

MF-4824-ADJT-LAM-CAS		48	24	29 - 47
MF-4830-ADJT-LAM-CAS		48	30	29 - 47
MF-4836-ADJT-LAM-CAS		48	36	29 - 47
MF-5424-ADJT-LAM-CAS		54	24	29 - 47
MF-5430-ADJT-LAM-CAS		54	30	29 - 47
MF-5436-ADJT-LAM-CAS		54	36	29 - 47
MF-6024-ADJT-LAM-CAS		60	24	29 - 47
MF-6030-ADJT-LAM-CAS		60	30	29 - 47
MF-6036-ADJT-LAM-CAS		60	36	29 - 47
MF-6624-ADJT-LAM-CAS		66	24	29 - 47
MF-6630-ADJT-LAM-CAS		66	30	29 - 47
MF-6636-ADJT-LAM-CAS		66	36	29 - 47
MF-7224-ADJT-LAM-CAS		72	24	29 - 47
MF-7230-ADJT-LAM-CAS		72	30	29 - 47
MF-7236-ADJT-LAM-CAS		72	36	29 - 47

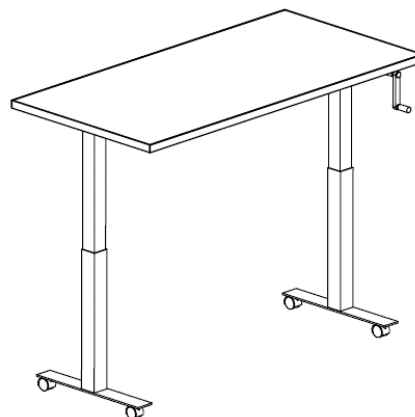
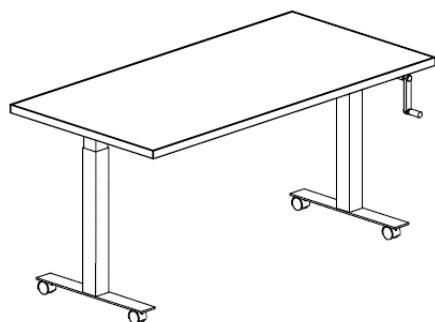

Hand-crank, adjustable height (29" - 47" AFF) / caster base

**2024
Maker Flex Table
Specifications**

General Information

Maker Flex Tables are durable, functional work tables allowing for flexibility in program spaces. Powder coated steel table bases provide strength and casters provide mobility. Choose either a high-pressure laminate or maple butcher block top, available at a fixed height or as height-adjustable. Nesting/flip top also available. Optional: adjustable glides in lieu of casters. Tables are unassembled and ship flat.

Maker Flex™ Table Nesting / Flip-Top Standards:

Height-adjustable Worksurface range is 27" - 41" above finish floor (AFF) with casters
Retractable hand crank located on end of table

Worksurface is 1-1/4" thick MDF with standard laminate surface & edge banding

Standard Laminates are available from Wilsonart, Formica, Pionite and Nevamar

Powder coated base available in Platinum Metallic, Black, White and Silver

Other colors available for 5% upcharge

Locking casters

Tables that are 72" long or 36" deep have two (2) release handles



shown with platinum metallic powder coated base

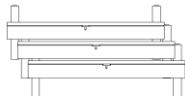
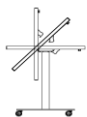

24" deep storage depth = 18" + (# tables - 1) x 7.25"

30" deep storage depth = 22" + (# tables - 1) x 7.25"

36" deep storage depth = 26" + (# tables - 1) x 7.25"

ITEM#	DESCRIPTION	WIDTH	DEPTH	HEIGHT
-------	-------------	-------	-------	--------

maker flex tables HP Laminate top - nesting / adjustable height 27"-41" h

MF-4824-NEST-ADJT-LAM-CAS		48	24	27 - 41
MF-4830-NEST-ADJT-LAM-CAS		48	30	27 - 41
MF-4836-NEST-ADJT-LAM-CAS		48	36	27 - 41
MF-5424-NEST-ADJT-LAM-CAS		54	24	27 - 41
MF-5430-NEST-ADJT-LAM-CAS		54	30	27 - 41
MF-5436-NEST-ADJT-LAM-CAS		54	36	27 - 41
MF-6024-NEST-ADJT-LAM-CAS		60	24	27 - 41
MF-6030-NEST-ADJT-LAM-CAS		60	30	27 - 41
MF-6036-NEST-ADJT-LAM-CAS		60	36	27 - 41
MF-6624-NEST-ADJT-LAM-CAS		66	24	27 - 41
MF-6630-NEST-ADJT-LAM-CAS		66	30	27 - 41
MF-6636-NEST-ADJT-LAM-CAS		66	36	27 - 41
MF-7224-NEST-ADJT-LAM-CAS		72	24	27 - 41
MF-7230-NEST-ADJT-LAM-CAS		72	30	27 - 41
MF-7236-NEST-ADJT-LAM-CAS		72	36	27 - 41

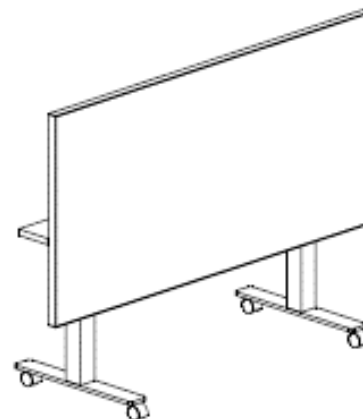
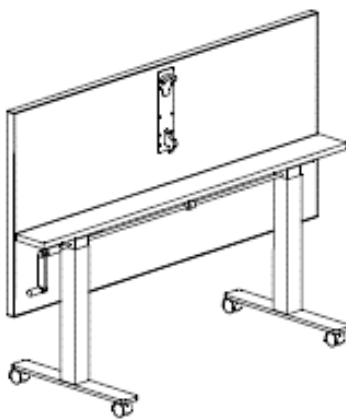
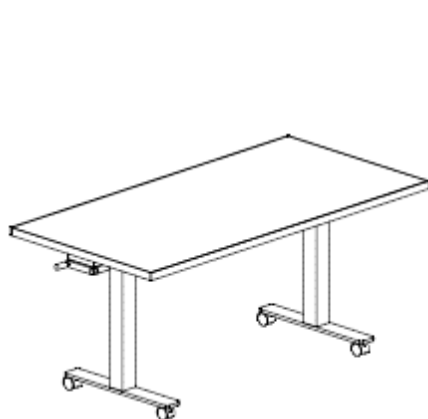

Flip-top, hand-crank, adjustable height (27" - 41" AFF) / caster base

**2024
Maker Flex Table
Specifications**

General Information

Maker Flex Tables are durable, functional work tables allowing for flexibility in program spaces. Powder coated steel table bases provide strength and casters provide mobility. Choose either a high-pressure laminate or maple butcher block top, available at a fixed height or as height-adjustable. Nesting/flip top also available. Optional: adjustable glides in lieu of casters. Tables are unassembled and ship flat.

Maker Flex™ Table Fixed Height Standards:

Fixed Worksurface 29" or 36" above finish floor (AFF) with casters
 Worksurface is 1-1/2" thick, solid maple butcher block with eased corners & edges
 Powder coated base available in Platinum Metallic, Black, White and Silver
 Other colors available for 5% upcharge
 Locking casters



shown with platinum metallic powder coated base

ITEM#	DESCRIPTION	WIDTH	DEPTH	HEIGHT
-------	-------------	-------	-------	--------

maker flex tables Maple Butcher Block top - seated height 29"h

- MF-482429-FIXT-BBK-CAS
- MF-483029-FIXT-BBK-CAS
- MF-483629-FIXT-BBK-CAS
- MF-542429-FIXT-BBK-CAS
- MF-543029-FIXT-BBK-CAS
- MF-543629-FIXT-BBK-CAS
- MF-602429-FIXT-BBK-CAS
- MF-603029-FIXT-BBK-CAS
- MF-603629-FIXT-BBK-CAS
- MF-662429-FIXT-BBK-CAS
- MF-663029-FIXT-BBK-CAS
- MF-663629-FIXT-BBK-CAS
- MF-722429-FIXT-BBK-CAS
- MF-723029-FIXT-BBK-CAS
- MF-723629-FIXT-BBK-CAS

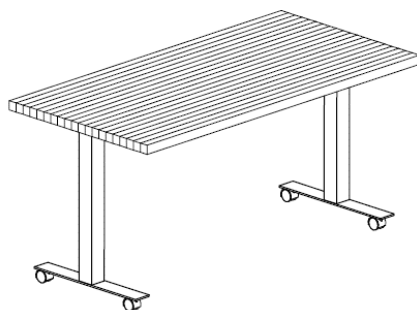

48	24	29
48	30	29
48	36	29
54	24	29
54	30	29
54	36	29
60	24	29
60	30	29
60	36	29
66	24	29
66	30	29
66	36	29
72	24	29
72	30	29
72	36	29

Fixed seated height (29" AFF) / caster base

maker flex tables Maple Butcher Block top - counter height 36"h

- MF-482436-FIXT-BBK-CAS
- MF-483036-FIXT-BBK-CAS
- MF-483636-FIXT-BBK-CAS
- MF-542436-FIXT-BBK-CAS
- MF-543036-FIXT-BBK-CAS
- MF-543636-FIXT-BBK-CAS
- MF-602436-FIXT-BBK-CAS
- MF-603036-FIXT-BBK-CAS
- MF-603636-FIXT-BBK-CAS
- MF-662436-FIXT-BBK-CAS
- MF-663036-FIXT-BBK-CAS
- MF-663636-FIXT-BBK-CAS
- MF-722436-FIXT-BBK-CAS
- MF-723036-FIXT-BBK-CAS
- MF-723636-FIXT-BBK-CAS

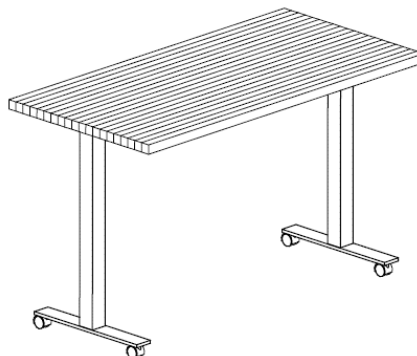

48	24	36
48	30	36
48	36	36
54	24	36
54	30	36
54	36	36
60	24	36
60	30	36
60	36	36
66	24	36
66	30	36
66	36	36
72	24	36
72	30	36
72	36	36

Fixed counter height (36" AFF) / caster base

**2024
Maker Flex Table
Specifications**

General Information

Maker Flex Tables are durable, functional work tables allowing for flexibility in program spaces. Powder coated steel table bases provide strength and casters provide mobility. Choose either a high-pressure laminate or maple butcher block top, available at a fixed height or as height-adjustable. Nesting/flip top also available. Optional: adjustable glides in lieu of casters. Tables are unassembled and ship flat.

Maker Flex™ Nesting / Flip-Top - Fixed Height Standards:

Nesting / Flip top Worksurface is 29" or 36" above finish floor (AFF) with casters
 Worksurface is 1-1/2" thick, solid maple butcher block with eased corners & edges
 Powder coated base available in Platinum Metallic, Black, White and Silver
 Other colors available for 5% upcharge
 Locking casters
 Tables that are 72" long or 36" deep have two (2) release handles



shown with platinum metallic powder coated base

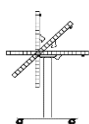

24" deep storage depth = 18" + (# tables - 1) x 7.25"
 30" deep storage depth = 22" + (# tables - 1) x 7.25"
 36" deep storage depth = 26" + (# tables - 1) x 7.25"

ITEM#	DESCRIPTION	WIDTH	DEPTH	HEIGHT
-------	-------------	-------	-------	--------

maker flex tables Maple Butcher Block top - nesting / seated height 29"h

- MF-482429-NEST-FIXT-BBK-CAS
- MF-483029-NEST-FIXT-BBK-CAS
- MF-483629-NEST-FIXT-BBK-CAS
- MF-542429-NEST-FIXT-BBK-CAS
- MF-543029-NEST-FIXT-BBK-CAS
- MF-543629-NEST-FIXT-BBK-CAS
- MF-602429-NEST-FIXT-BBK-CAS
- MF-603029-NEST-FIXT-BBK-CAS
- MF-603629-NEST-FIXT-BBK-CAS
- MF-662429-NEST-FIXT-BBK-CAS
- MF-663029-NEST-FIXT-BBK-CAS
- MF-663629-NEST-FIXT-BBK-CAS
- MF-722429-NEST-FIXT-BBK-CAS
- MF-723029-NEST-FIXT-BBK-CAS
- MF-723629-NEST-FIXT-BBK-CAS

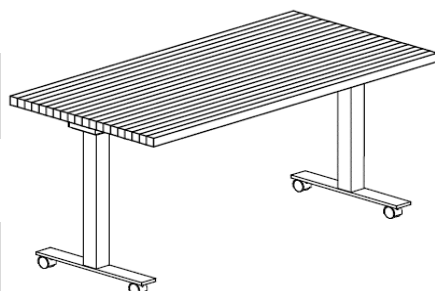

48	24	29
48	30	29
48	36	29
54	24	29
54	30	29
54	36	29
60	24	29
60	30	29
60	36	29
66	24	29
66	30	29
66	36	29
72	24	29
72	30	29
72	36	29

Fixed seated height (29" AFF) / caster base

maker flex tables Maple Butcher Block top - nesting / counter height 36"h

- MF-482436-NEST-FIXT-BBK-CAS
- MF-483036-NEST-FIXT-BBK-CAS
- MF-483636-NEST-FIXT-BBK-CAS
- MF-542436-NEST-FIXT-BBK-CAS
- MF-543036-NEST-FIXT-BBK-CAS
- MF-543636-NEST-FIXT-BBK-CAS
- MF-602436-NEST-FIXT-BBK-CAS
- MF-603036-NEST-FIXT-BBK-CAS
- MF-603636-NEST-FIXT-BBK-CAS
- MF-662436-NEST-FIXT-BBK-CAS
- MF-663036-NEST-FIXT-BBK-CAS
- MF-663636-NEST-FIXT-BBK-CAS
- MF-722436-NEST-FIXT-BBK-CAS
- MF-723036-NEST-FIXT-BBK-CAS
- MF-723636-NEST-FIXT-BBK-CAS

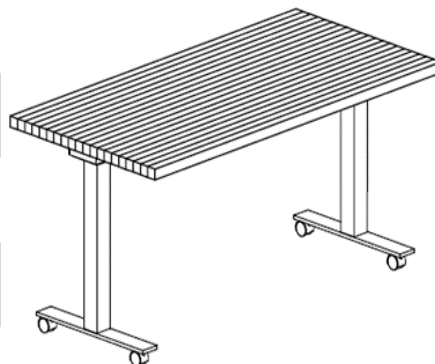

48	24	36
48	30	36
48	36	36
54	24	36
54	30	36
54	36	36
60	24	36
60	30	36
60	36	36
66	24	36
66	30	36
66	36	36
72	24	36
72	30	36
72	36	36

Fixed counter height (36" AFF) / caster base

**2024
Maker Flex Table
Specifications**

General Information

Maker Flex Tables are durable, functional work tables allowing for flexibility in program spaces. Powder coated steel table bases provide strength and casters provide mobility. Choose either a high-pressure laminate or maple butcher block top, available at a fixed height or as height-adjustable. Nesting/flip top also available. Optional: adjustable glides in lieu of casters. Tables are unassembled and ship flat.

Maker Flex™ Table Height-adjustable Standards:

Height-adjustable Worksurface range is 29" - 47" above finish floor (AFF) with casters

Retractable hand crank located on patron side of table

Worksurface is 1-1/2" thick, solid maple butcher block with eased corners & edges

Powder coated base available in Platinum Metallic, Black, White and Silver

Other colors available for 5% upcharge

Locking casters

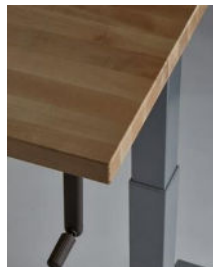

shown with platinum metallic powder coated base

ITEM#	DESCRIPTION	WIDTH	DEPTH	HEIGHT
-------	-------------	-------	-------	--------

maker flex tables Maple Butcher Block top - adjustable height 29"-47"h

MF-4824-ADJT-BBK-CAS		48	24	29 - 47
MF-4830-ADJT-BBK-CAS		48	30	29 - 47
MF-4836-ADJT-BBK-CAS		48	36	29 - 47
MF-5424-ADJT-BBK-CAS		54	24	29 - 47
MF-5430-ADJT-BBK-CAS		54	30	29 - 47
MF-5436-ADJT-BBK-CAS		54	36	29 - 47
MF-6024-ADJT-BBK-CAS		60	24	29 - 47
MF-6030-ADJT-BBK-CAS		60	30	29 - 47
MF-6036-ADJT-BBK-CAS		60	36	29 - 47
MF-6624-ADJT-BBK-CAS		66	24	29 - 47
MF-6630-ADJT-BBK-CAS		66	30	29 - 47
MF-6636-ADJT-BBK-CAS		66	36	29 - 47
MF-7224-ADJT-BBK-CAS		72	24	29 - 47
MF-7230-ADJT-BBK-CAS		72	30	29 - 47
MF-7236-ADJT-BBK-CAS		72	36	29 - 47

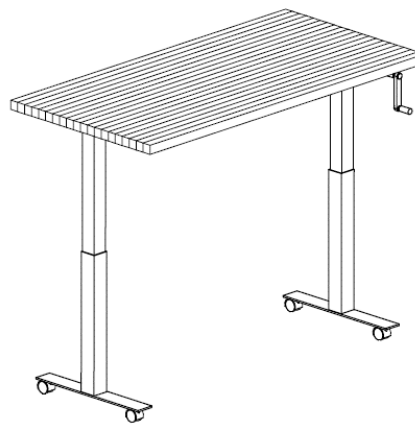
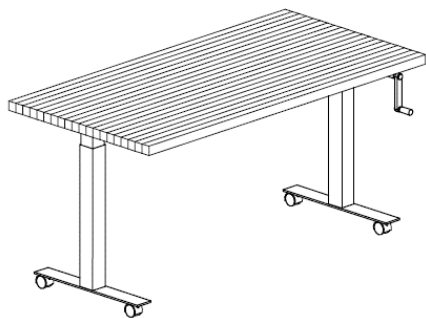

Hand-crank, adjustable height (29" - 47" AFF) / caster base

**2024
Maker Flex Table
Specifications**

General Information

Maker Flex Tables are durable, functional work tables allowing for flexibility in program spaces. Powder coated steel table bases provide strength and casters provide mobility. Choose either a high-pressure laminate or maple butcher block top, available at a fixed height or as height-adjustable. Nesting/flip top also available. Optional: adjustable glides in lieu of casters. Tables are unassembled and ship flat.

Maker Flex™ Table Nesting / Flip-Top Standards:

- Height-adjustable Worksurface range is 27" - 41" above finish floor (AFF) with casters
- Retractable hand crank located on end of table
- Worksurface is 1-1/2" thick, solid maple butcher block with eased corners & edges
- Powder coated base available in Platinum Metallic, Black, White and Silver
- Other colors available for 5% upcharge
- Locking casters
- Tables that are 72" long or 36" deep have two (2) release handles



shown with platinum metallic powder coated base

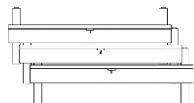
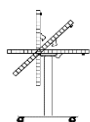

24" deep storage depth = 18" + (# tables - 1) x 7.25"
 30" deep storage depth = 22" + (# tables - 1) x 7.25"
 36" deep storage depth = 26" + (# tables - 1) x 7.25"

ITEM#	DESCRIPTION	WIDTH	DEPTH	HEIGHT
-------	-------------	-------	-------	--------

maker flex tables Maple Butcher Block top - nesting / adjustable height 27"-41"h

MF-4824-NEST-ADJT-BBK-CAS		48	24	27 - 41
MF-4830-NEST-ADJT-BBK-CAS		48	30	27 - 41
MF-4836-NEST-ADJT-BBK-CAS		48	36	27 - 41
MF-5424-NEST-ADJT-BBK-CAS		54	24	27 - 41
MF-5430-NEST-ADJT-BBK-CAS		54	30	27 - 41
MF-5436-NEST-ADJT-BBK-CAS		54	36	27 - 41
MF-6024-NEST-ADJT-BBK-CAS		60	24	27 - 41
MF-6030-NEST-ADJT-BBK-CAS		60	30	27 - 41
MF-6036-NEST-ADJT-BBK-CAS		60	36	27 - 41
MF-6624-NEST-ADJT-BBK-CAS		66	24	27 - 41
MF-6630-NEST-ADJT-BBK-CAS		66	30	27 - 41
MF-6636-NEST-ADJT-BBK-CAS		66	36	27 - 41
MF-7224-NEST-ADJT-BBK-CAS		72	24	27 - 41
MF-7230-NEST-ADJT-BBK-CAS		72	30	27 - 41
MF-7236-NEST-ADJT-BBK-CAS		72	36	27 - 41

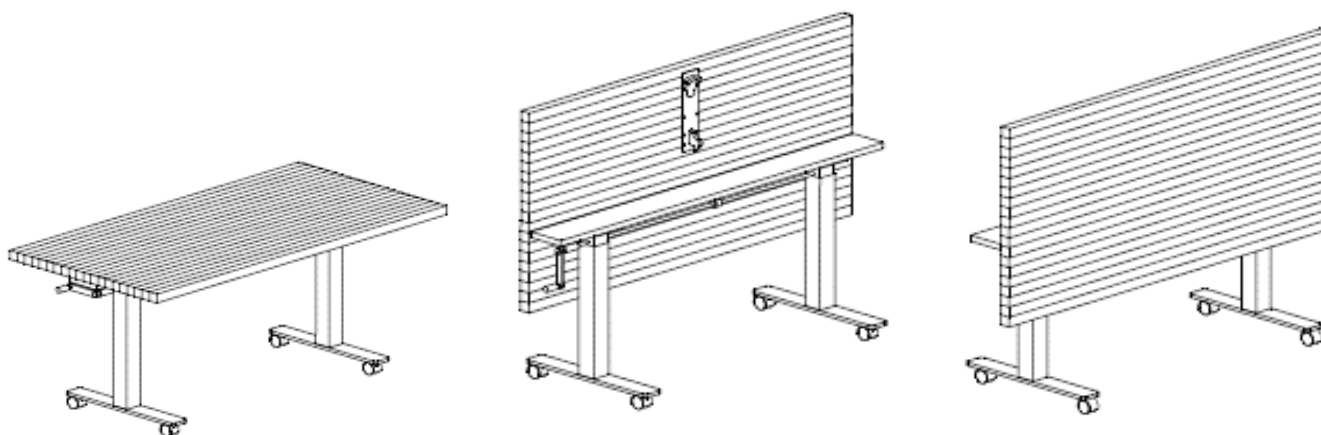

Flip-top, hand-crank, adjustable height (27" - 41" AFF) / caster base

**2024
Maker Flex Table
Specifications**

Maker Flex™ Tables Radius Corner Option

Rounded corners with 3" radius
Available for both laminate & butcher block tops



shown with white powder coated base

ITEM#	DESCRIPTION	WIDTH	DEPTH	HEIGHT
-------	-------------	-------	-------	--------

maker flex tables radiused corner optional add-on

RADIUS-CORNER-LAMINATE

RADIUS-CORNER-BUTCHERBLOCK

